



OUTBACK SERIES OWNER'S MANUAL



IMPORTANT INFORMATION ENCLOSED

Some of the information contained in this manual may not relate to your specific Imperial. This manual covers multiple models and configurations, therefore, some information contained within may relate to options not installed on all units.

Information contained within this manual is subject to change without notice.

• **Before operating your Imperial RV:** Please read ALL of the important information provided in the Owner's Manual as well as the individual manuals in your New Owner Packet. We at Nelson Industries, as well as your Imperial Dealer, want you to have a safe and enjoyable time using your Imperial RV. Reading and complying with this important information and knowing how to safely operate and maintain your Imperial is the best way to ensure years of enjoyment with your new purchase.

• Be sure to read and save this and all of the individual component's manuals included with your New Owner's Packet. They will show you how to safely operate and maintain each of the appliances in your Imperial. The individual manuals also contain the contact information for each of the component's manufactures and may include warranty registration forms for remittance.

Table of Contents

Rev. 09-2025

Thank you for choosing Imperial Outdoors as your new RV. This owner's manual is designed as a reference guide for the safe operation, proper care and maintenance of your new Imperial RV. For more complete instructions regarding safety, maintenance and operation of the individual components installed and used in the manufacturing of your RV, please carefully read each individual component's manufacturer's manuals and booklets supplied by the individual component manufacturers and send in all manufacturer's required warranty registrations.

NOTICE: The component manufacturer's instructions, manuals and warranties precede, come first, and replace all information contained in this Owner's Manual, Instructions and Warranty.

Warranty Summary	3
Taking Delivery of New Imperial.	5
Responsibilities	5
Imperial Dealer Responsibilities	5
Imperial Owner Responsibilities	5
Get to Know Your Unit	5
Pre-Travel Checklist.	5
Running Gear Safety & Maintenance	6
General Maintenance.	6
Maintenance Schedule	6
Torque Requirements.	7
Electric Drum Brakes	8
Wheel Bearing Maintenance	12
Tires, Maintenance, Load Limits & Safety	12
Frame & Frame Maintenance	12
Proper Loading & Balancing of Trailer.	12
Tongue Weight	13
Trailer Load Limits	13
Safety Tow Chains	14
Leveling your Imperial	14
Electrical.	14
Exterior Running Lights	14
12V Electric Brakes, Electric Break Away	14
30 amp AC Power Cord Adapter	14
Battery Charger Operation (110v).	14
Electrical Converter Operation	14
12V Power Converter	14
110V GFCI (Ground Fault Circuit Interruptor).	15
110V Circuit Breakers.	15
12V DC & 12V DC Fuses.	15
Battery Installation, Operation & Charging	15
Battery Maintenance	15
Battery Safety	16
Battery Charging	16
Fire Safety.	16
Smoke Detector Operation.	16
CO/LP Detector.	16
In Event of LP Detector Alarm	16
Fire Extinguisher Operation	16
LP System Operation.	17
LP System	17
LP Regulator	17
LP Pigtail	17
Propane (LP) Containers	17
Furnace & Thermostat	18
Furnace & Thermostat Operation	18
Troubleshooting Furnace	18
Air Conditioning System	19
A/C Operation & Maintenance	19

Cooktop Operation	19
Water System	19
Maintenance	20
Condensation	20
Prolonged Occupancy	21
Frame, Extrusions & Aluminum Surfaces	21
Roof	21
Siding	21
Seals & Adhesives	21
Windows & Doors	21
Exterior Cleaning	21
Storing Your Imperial	21
Winterizing Your Imperial	22
Chemical Advisory	25
Component List	25
Parts Reference	25
Notes	26

Warranty Summary

LIMITED 1 YEAR WARRANTY

COVERAGE: Nelson Industries, Inc., (NI) - 2191 Aspen Street, St. Croix Falls, WI 54024, Manufacturer of RVs (Warrantor) warrants to the ORIGINAL CONSUMER PURCHASER ONLY (Purchaser), when purchased from an Authorized Imperial Dealer, for a period of (1) one year from the purchase (Warranty Period), that the body structure of this Imperial RV shall be free of substantial defects in materials and workmanship attributable to Warrantor.

EXCLUSIONS FROM THIS WARRANTY: Warrantor expressly disclaims any responsibility for damage to the unit where damage is due to condensation, normal wear and tear or exposure to elements. Warrantor makes no warranty with regard to, but not limited to, the chassis including without limitation, any mechanical parts or systems of the chassis, axles, tires, tubes, and batteries, required routine maintenance, equipment and appliances, or audio and/or video equipment. Their respective manufacturers and suppliers may warrant some of these items. Warranty information with respect to these items is included with your Imperial New Owners Packet or may be available from your dealer or the individual Component Manufacturer.

No action to enforce express or implied warranties shall be commenced without prior written notice to the manufacturer and/or warrantor at the address listed above of the alleged defect or nonconformity or the authorized repair facility's failed repair attempt and MANUFACTURE, AT ITS DIRECT OPTION, shall have a final opportunity to remedy.

WARRANTER'S OBLIGATIONS: Warrantor will remedy substantial defects in materials and workmanship caused by Warrantor. Warrantor shall elect to remedy the defect by repair or replacement. Warranty performance can only be obtained at Warrantor's facility (address above) or only upon prior approval from the Warrantor at Warrantor's authorized dealer service center, at the discretion of the Warrantor. All costs incurred in transporting this recreational vehicle for warranty service shall be borne by Purchaser. Warrantor shall remedy the defect within a reasonable amount of time, after appointment and delivery by Purchaser. All of Warrantor's expenses in remedying the defect shall be borne by the Warrantor.

PURCHASER'S OBLIGATIONS: Purchaser and Imperial Dealer must complete, sign and return the owner's registration within (10) ten days of purchase date to validate this Warranty. The return of this registration is a condition precedent to warranty coverage; failure to return the completed registration to the Warrantor within (10) ten days from the purchase date will invalidate this warranty. Purchaser shall deliver this recreational vehicle for warranty service within a reasonable time after discovery of the defect and in no event after expiration of the Warranty period, which Warranty Period is (1) one year. All expenses incurred by Purchaser in obtaining warranty service shall be borne by Purchaser. Warranty service shall, whenever possible, be scheduled with or through the selling dealer, by an appointment in order to avoid possible delays. No action to enforce express or implied warranties shall be commenced without prior written notice to the manufacturer and/or warrantor at the address listed above of the alleged defect or nonconformity or the authorized repair facility's failed repair attempt and MANUFACTURER, AT ITS DIRECT OPTION, shall have a final opportunity to remedy.

EVENTS DISCHARGING WARRANTOR FROM OBLIGATION UNDER THIS WARRANTY: Misuse or neglect, including but not limited to failure to provide reasonable and necessary maintenance, unauthorized alteration, accident, and improper loading, use as a permanent residence, commercial use, rental or leasing of the recreational vehicle shall discharge Warrantor from any obligation under this Warranty.

PARTS AND DESIGN CHANGES: Warrantor reserves the right to change the parts and design of its recreational vehicle at any time without notice and with no obligation to maintain spare parts or make corresponding changes in its products previously manufactured.

OWNER ASSISTANCE: Your confidence is important to us at NI, as is maintaining a pleasant relationship with our Imperial Dealers. NI recognizes that there may be occasions when a warranty or service problem is not handled to your satisfaction, resulting in misunderstandings.

After discussing the situation with your Imperial Dealership management, if your problem has not been resolved to your satisfaction we welcome you to contact NI at the address listed above (and on the back of this manual). We will be happy to work with you and your Imperial Dealer in an attempt to resolve the situation.

THIS WARRANTY GIVES YOU SPECIFIC LEGAL RIGHTS, AND YOU MAY ALSO HAVE OTHER RIGHTS, WHICH VARY FROM STATE TO STATE AND PROVINCE.

Warranty Summary (cont...)

Rev. 09-2025

Limited Warranty (Frame)

NOTICE: This agreement is between the ORIGINAL PURCHASER and GS TRAILERS. GS Trailers, Inc, will warrant their products to be free from defective workmanship and materials in normal use and service for a period of TWO (2) years from the date of delivery to the purchaser. The warranty hereby covers any defects of workmanship and materials used in the structure of the trailer: i.e. the frame, side rails, cross members, welds, and sub frame assemblies.

Limitations of GS Trailers Warranty

GS Trailers does NOT warrant components not manufactured by GS Trailers. Therefore, this warranty does NOT cover axles and axle components, tires, wheels, couplers, jacks, suspension components, springs, wiring, lights, paint (including chipping, fading, and aging), accessories, or any other component not manufactured by GS Trailers. If these items are warranted by the manufacture or supplier thereof and warranty may be extended to the purchaser, GS Trailers will make such warranties available.

Exclusions of GS Trailers Warranty

- 1) Normal wear on any item will not be subject to warranty. Normal wear items, include, brakes, tires, bearings, axle seals, light bulbs, and fading or cracking of flooring; but are not limited exclusively to these items.
- 2) Any damage done due to lack of good industry maintenance such as improper bearing adjustment, incorrect air pressure, lug nut torque, etc. will also not be covered by GS Trailers Warranty.
- 3) Any damage to the frame, axles, tires, or any other component due to overloading or abuse is not covered under warranty
- 4) Coatings offered by GS Trailers are for aiding to the longevity of the trailer. Coatings in high rub / pivot areas are not covered under the warranty. This includes the front pinning area and axle pivot areas. Coatings that have been cut, scraped, peeled, or not maintained, are not covered under the warranty.
- 5) Trailers used for rental are not covered under this limited warranty.

In the event of a defect in material or workmanship covered by this warranty, GS Trailers will:

- 1) Correct the defective work or replace the defective parts on a no-charge basis at our plant location, or
- 2) Reimburse the purchaser by paying a sum not exceeding the price charged by GS Trailers for such work, or
- 3) Provide for repair of the defect or replacement of the defective parts by an authorized shop.

It is the sole decision of GS Trailers to determine the best method of repair.

All Warranty repairs must be pre-authorized by GS Trailers before any reimbursements shall be made. GS Trailers will likely require photographs of items that are thought to be defective in order to approve reimbursements. All freight charges to or from the factory or pre-authorized repair facility is the responsibility of the purchaser. ALL FREIGHT IS EXEMPT FROM WARRANTY. In addition, this warranty does NOT cover any economic loss including but not limited to; payment for the loss of time or pay, inconvenience, loss of trailer use, lodging bills, trailer rental expense, meals, storage charges, and other incidental or consequential loss or damage of similar nature. This warranty will be void if the trailer is damaged due to overloading, negligence, or misuse. Without prior approval, any modifications or alterations to any product or part manufactured by GS Trailers will void the warranty IN ITS ENTIRETY. Weights, dimensions, capacities and other measures stated in connection with the new trailer are only estimates and are not covered by this warranty.

DISCLAIMERS

THIS WARRANTY IS EXPRESSLY IN LIEU OF ALL OTHER EXPRESS WARRANTIES AND REPRESENTATIONS. GS TRAILERS MAKES NO OTHER REPRESENTATION OR WARRANTY OF ANY KIND, EXPRESS OR IMPLIED, WITH RESPECT TO GS TRAILERS. NO ONE BESIDES AN AUTHORIZED GS TRAILER REPRESENTATIVE IS AUTHORIZED TO MAKE FURTHER OR ADDITIONAL WARRANTIES ON BEHALF OF GS TRAILERS.

THIS WARRANTY IS NON-TRANSFERABLE.

Imperial Warranty Overview

Your new Imperial comes with a 1 year warranty that includes all material and workmanship defects that may occur.

If you need warranty work performed by Imperial at the Nelson Industries facility, it is the owner's responsibility to deliver and pick up the RV to and from our manufacturing facility located at: 2191 Aspen Street, St. Croix Falls, WI. Any hauling done by Nelson Industries, Inc. or anyone else that is affiliated with NI may be subject to a minimum charge of \$1.75 per mile.

Some items that are not covered by the Imperial Warranty are:

- Individual Components Manufactured by others
- Rust on the Frame
- Wavy Siding caused by expanding and contracting due to heat or cold.
- Any Damage or Issues caused by excessive use, abuse, neglect or misuse by the owner.

Send in your Imperial and Individual Component Manufactures Warranty registrations cards within ten (10) days of purchase.

Failure to do so could void these important warranties.

Please, contact the Imperial Dealer you purchased your Imperial RV from for ANY warranty issues.

Your Imperial Dealer is your FIRST contact for any warranty or non-warranty related issues. Many Imperial Dealers are capable of addressing and/or performing some or all of the warranty or non-warranty services that may arise.

You may contact your Imperial Dealer for help with obtaining warranty service from the individual component Manufacturer. Many Imperial Dealers are capable of performing warranty service for these companies and/or can assist you with getting warranty service from the individual component Manufacturers.

OR

You may also contact the Manufacturer of the individual component for warranty service. You can find many of the individual component Manufacturer's contact information in the specific manuals included in your Imperial Owners Packet. Please review the individual component Manufacturer's manuals in your Imperial Owners Packet.

Taking Delivery of your New Imperial

When picking up your New Imperial from your Imperial Dealer you will complete two important documents: the Dealer / Customer Delivery Check List and the Imperial Warranty Registration Card. These are important documents and information. Every Imperial Dealer and New Owner must complete the Dealer / Customer Delivery Check List, together, and perform a 'walk-through' of your new Imperial with you to ensure that you have been shown the proper safe use and care of each component of your new RV. If you did not complete a Dealer / Customer Delivery Check List and Imperial Warranty Registration Card and perform a complete 'walk-through' with your Dealer, please contact your Imperial Dealer immediately and complete these important documents and instructions. Be sure to completely understand information and proper functioning of each of the components of your New Imperial to ensure you have a safe and enjoyable experience!

Responsibilities

Rev. 09-2025

Imperial Dealer Responsibilities

Your Imperial Dealer is responsible for performing a Pre-delivery inspecting of both the Imperial Factory and Dealership installed components on your Imperial RV for proper operation.

Your Imperial Dealer is required to provide you with a complete and thorough 'walk-through' of the operation, use and care of each component of your Imperial RV before you take possession of the your Imperial. NI and your Imperial Dealer want you to know the complete and safe operation of each component.

Your Imperial Dealer is required to provide you with and review a complete Imperial Owner's Manual and provide you with Imperial Owner's Packet that includes all the operation manuals and warranty registrations cards for individual components installed on your Imperial RV.

Imperial Owner Responsibilities

As the Owner of an Imperial RV, you have the responsibility to understand the complete, safe and proper operation and maintenance of your unit and each component installed. You are responsible to properly maintain your new Imperial and have periodic and preventative maintenance performed in a timely manner, and properly winterize your RV if necessary. Please do not ignore proper maintenance or ignore problems. Complete and send in all warranty registrations cards. This will ensure the individual component manufactures enact (start) your warranty and have your contact information so they may contact you regarding any warranty or recalls on their products installed on your New Imperial RV in a timely manner.

NOTICE: Your Imperial RV was not designed to be used as a permanent dwelling, rather for recreational use. Use of your Imperial as a permanent dwelling, rental property or commercial use may reduce or possibly void your warranty coverage.

Get to Know Your Unit Before Heading Out

Throughout the manufacturing process, your recreational vehicle has been inspected by qualified inspectors and then again at the dealership. As the owner, however, you will be the first to camp and extensively use every system. Imperial Outdoors wants your first camping experience to be happy one and recommends a "trial camping experience" before heading out. Plan a weekend out in your yard or driveway and camp in your unit. By camping in your unit, at home, you will have the opportunity to use and become accustomed to the systems within your unit and find out what items are needed or not needed while camping. Note any questions that arise, difficulties encountered or problems that occur. After your trial, call your dealer and ask any questions that have arisen. Taking the opportunity to become familiar with your unit will prevent frustration and help to make your first camping experience more relaxing!

Pre-Travel Checklist

Rev. 09-2025

Notice to ALL BUYER - Before traveling with your Imperial RV ALWAYS:

1. SHUT OFF ALL GAS APPLIANCES BEFORE REFUELING TOW VEHICLE!
2. Check tire lug nuts to confirm that they are tight each time you travel.
3. Check tire inflation pressure and inspect tires for damage or wear.
4. Set and check trailer brake system on tow vehicle (if equipped).
5. Connect trailer safety breakaway cable.
6. Make sure hitch is properly locked with safety chains attached.
7. Plug 7-pin connector into tow vehicle and check running lights/signals.
8. Release parking brake (if equipped).
9. Make sure the entry door and storage compartments are locked.
10. Make sure toy hauler ramp door is secured and locked (if equipped).
11. Make sure windows are closed.
12. Make sure external electrical is disconnected.
13. Make sure water and drain connections are disconnected.
14. Make sure upper bunks are secured (if equipped).
15. Make sure personal items in trailer are properly stowed and secured.
16. Make sure your trailer is properly balanced and not overweight!

NOTICE: TOWING AT SPEEDS IN EXCESS OF 55 MILES PER HOUR CAN INCREASE THE RISK OF SWAY OR UNEXPECTED BEHAVIOR!

GENERAL MAINTENANCE

CruiseMaster™ suspensions and axle systems have been designed to give a trouble free life with minimum maintenance. However, to ensure the safety and reliable operation of your suspension system the following routine maintenance must be carried out. The service periods recommended below are based on normal road usage. For off-road and abnormal conditions maintenance intervals will need to be more frequent and daily visual inspections are recommended. Maintenance should be carried out by a competent person.

The suspension fitted has been selected according to the vehicle manufacturers recommended Aggregate Trailer Mass (ATM) which can be found on the vehicles compliance plate. It is important that these figures are not exceeded.

MAINTENANCE SCHEDULE	INITIAL CHECKS, AT		SERVICE INTERVALS, EVERY
	1st 60mi	1st 600mi	6,000mi or 12 months
Wheel Nuts Tightened	☑	☑	☑
Torque Suspension & Shock Mounting Bolts		☑	☑
Grease Hinge Bushes		☑	☑
Inspect Bushes			☑
Shock Absorbers Visual Inspection			☑
Wheel Bearings Check		☑	☑
Wheel Bearings Service			☑
Check Brake Mounting Bolts for Tightness		☑	☑
Brake Adjustment & Check		☑	☑
Brake Service			☑
Wheel Alignment		☑	☑

NOTE: If your suspension is spending significant time on dirt roads, or has experienced rough terrain, we strongly recommend that your suspension be serviced more regularly. Failure to properly maintain your suspension may void any manufacturer's warranty.

For a full list of spare and replace parts refer to the Installation Instructions available via; www.cruiseMASTER.com.au/downloads/.



1 TIGHTNESS OF WHEEL NUTS

When a wheel is first fitted or removed there is an immediate settling in period where the wheels nuts will need retightening. Trailers tend to experience higher wheel loads than cars especially in tandem configuration and so extra effort should be taken to ensure wheel nuts remain tight. Proceed as follows:

1. Make sure the wheel and hub mating surfaces, as well as the wheel studs and nuts, are free of oil and all foreign material. Do not lubricate wheel studs.
2. Install the wheel and hand-tighten the wheel nuts.
3. Using a wheel or air wrench, lightly tighten all the wheel nuts, in a criss-cross pattern, until they are snug.
4. Lower the vehicle to the ground
5. Using a torque wrench, tighten the wheel nuts in a criss-cross pattern to the vehicle manufacturer's torque specification. If no specification is available, use wheel nut torque figures given in Table 3: Recommended Wheel Stud Torque Settings.

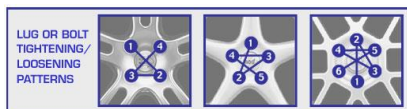

TORQUE REQUIREMENTS

The torque figures quoted are applicable to fasteners in a clean and unlubricated condition, free from rust or corrosion. Correct pre-loading of the bolt resists the effects of fatigue. Providing that the bolt pre-load is greater than the applied load, the fatigue life of the bolt will be infinite. Always use a torque wrench.

* For wheel stud torques refer to drum/stud section

IMPORTANT: Always remember that the best method for retaining a nut on a bolt is by proper tightening.

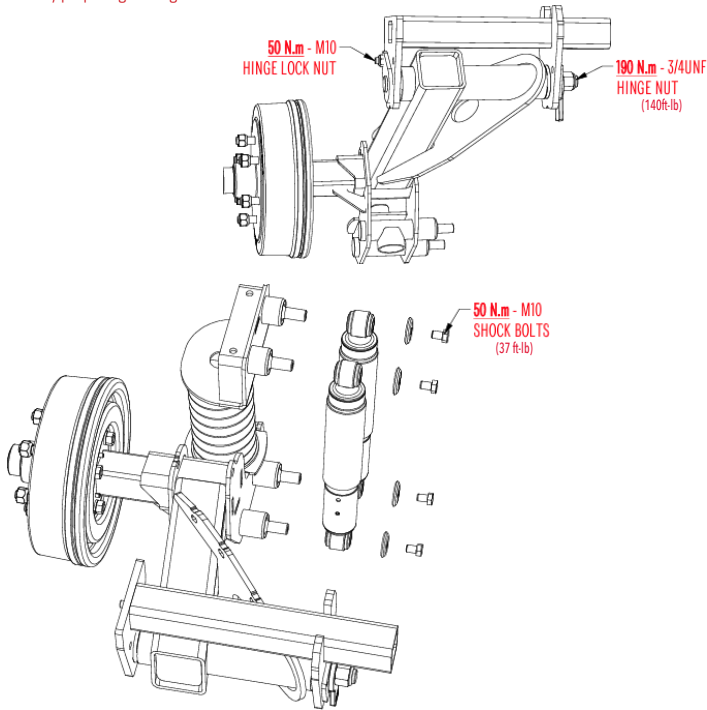

Cruisemaster™ highly recommends carrying a torque wrench when travelling remote.
(Not available through Cruisemaster™)

Torque figures given here are the maximum allowable for the supplied drum/hub studs.

IMPORTANT:

- Torque settings will need to be reduced depending on wheel rim design and type. Please consult the trailer manufacturer, wheel manufacturer or supplier for recommended specifications to suit the wheels supplied with your trailer.
- Maximum torque is based on 80% of stud yield strength.
- Wheel nuts should be tightened in a diagonal (criss-cross) sequence.
- Wheel nuts should be torqued using a calibrated torque wrench and checked at regular intervals as recommended in the maintenance schedule.

Stud Size	Grade	Maximum Stud Torque (ft-lb)
7/16" UNF	SAE Grade 8	88
1/2" UNF	SAE Grade 8	147
9/16" UNF	SAE Grade 8	199
5/8" UNF	SAE Grade 8	276
M12x1.5	Class 10.9	114
M14x1.5	Class 10.9	180

TABLE 3

Source: Cold Forged Products

Running Gear Safety & Maintenance (cont...)

Rev. 09-2025

DRUMS / HUBS - WHEEL MOUNTING & STUDS

DRUMS / HUBS

Cruisemaster™ offers a range of drum/hub options to suit most common wheel types. This not only includes a range of stud patterns but also the spigot size crucial to the correct mounting of wheels.

It is important to identify if the wheels and drums/hubs being used are designed for hub centric or stud centric mounting. This is vital in ensuring the wheel is correctly centred on the drum/hub. Failure to do so will result in excessive vibration which could potentially cause the wheel to become loose and/or studs to be sheared.

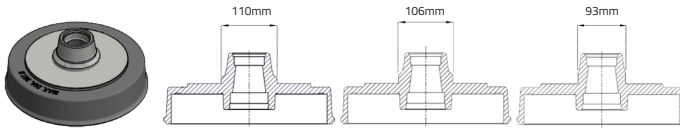

The spigot size is calculated at the point the spigot meets the drum face

Learn more about Wheel Mounting on YouTube: [▶ CruisemasterClass - Ep 9](#)

WHEEL STUDS

Please ensure if changing wheel nuts that they are suitable for the length of stud. When using close ended nuts we recommend running the nut down the length of the stud prior to fitting the wheel to ensure they do not bottom out on the available stud length.

When mounting the wheel ensure nuts are tightened in a criss-cross pattern first by hand then tightened to the vehicle manufacturer's torque specifications.

If a torque requirement has not been provided please refer to the table opposite for the **maximum** torque guidelines.

ELECTRIC DRUM BRAKES

Cruisemaster™ CRS2 suspension kits are fitted with Cruisemaster A/T brand backing plates. A range of Cruisemaster™ A/T spares are available directly from Cruisemaster or a number of caravan specialists around the country.

Components

1. Primary Shoe
2. Secondary Shoe
3. Magnet
4. Adjuster
5. Actuating Lever
6. Hold Down Spring
7. Retractor Spring
8. Handbrake Lever
9. Bowden Bracket
10. Activation Wires
11. Hand Indicator
12. Backing Plate

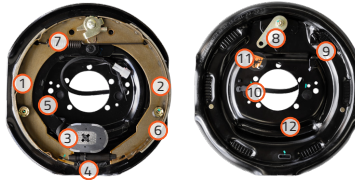

ELECTRIC DRUM BRAKES SET UP & MAINTENANCE

IMPORTANT:

Refer section "Maintenance Schedule / Servicing" for required service frequency

BRAKE BOLTS & TORQUE

BRAKE	PATTERN	BOLT	NUT	TORQUE
12x2" CRUISEMASTER™	5 HOLES 98.5 PCD UNEQUAL AS PICTURED	3/8" UNF x 3/4" GRADE 5 Z/P	3/8" CONELOCK GRADE C Z/P	24 ft-lb
10x2 1/2" CRUISEMASTER™	4 HOLES 101.6 PCD	--	7/16" CONELOCK GRADE C Z/P	39 ft-lb

GREASE HINGE BOLTS

Using grease gun, pump grease through grease nipples until it comes out around the bushes.

INSPECTION OF SUSPENSION BUSHES

Remove bushes, bolts, pins and spindles and inspect. Any parts showing signs of wear should be replaced. Smear a small amount of grease on bushes and outside of pins and spindles prior to reassembly. Torque all bolts in accordance with "Torque Requirements", ensuring that new Nylon Insert nuts are fitted where used.

SHOCK ABSORBERS

Visually inspect for leaks, if found leaking and within warranty period contact Cruisemaster™. If outside of warranty period replacement shocks are available online, over the counter or via a Cruisemaster™ NSN Member.

Check mounting bolts for tightness. Correct torque is critical for proper installation and trouble free service – Refer "Torque Requirements". When vehicle is rocked movement should stop within 3-4 applications.

Slight misting of oil on the exterior of the shock absorber is normal and does not indicate a fault. (as shown)



WHEEL BEARINGS

After first 1,000km: Check for excessive bearing play and adjust if necessary. Every 6 months or 10,000km: Wheel bearings should be dismantled and inspected. Lubricate with Castrol LMX grease or equivalent and replace bearings if necessary.

WHEEL ALIGNMENT

Refer to "Wheel Alignment" section for maintenance instructions.

Watch how to inspect & adjust wheel bearings on YouTube: [▶ CruisemasterClass - Ep 7](#)

WHEEL ALIGNMENT

A wheel alignment should be conducted every 10,000 Km's, or if abnormal tyre wear is occurring. Visually inspect tyres for abnormal wear more regularly during off-road use.

Cruisemaster™ CRS² independent suspension toe adjustment can be made with the cam mechanisms provided. This suspension has a degree of positive camber built in to ensure the wheels are aligned correctly under load. Wheels are recommended to have 0° to 0.5° negative camber at rated load.

If additional positive camber is required, offset hinge bushes are available. Contact the Cruisemaster Customer Service Team to learn more.

WHEEL ALIGNMENT PROCEDURE

1. Ensure the trailer is fully loaded and on a flat surface that will allow some tyre movement, move the trailer backwards and forwards to eliminate any twist in the wheels.

Do not climb under a vehicle which is only supported by jacks, ensure suitably rated vehicle stands are used.

2. Place a straight edge across the tyre face or drum face (avoiding inconsistencies from bulging lettering etc) then measure the distance from the straight edge to the chassis rail. This is your toe measurement.

(Wheels on a single or tandem front axle should be adjusted to between 2mm toe-in and parallel. Wheels on tandem rear axle should measure parallel from the chassis rail.)

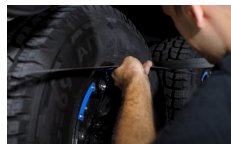

Running Gear Safety & Maintenance (cont...)

Rev. 09-2025

3. Toe is adjusted via the cam on the outside of the arm. Loosen the hinge nut and rotate the adjuster as required.

When adjustment is completed, tighten and torque hinge nut. (190 Nm)

If the necessary alignment has not been achieved, repeat procedure until satisfied.

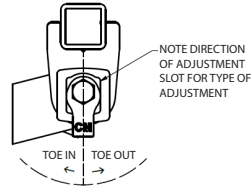

Watch how to complete a wheel alignment on YouTube: [▶ CruisemasterClass - Ep 5](#)

BRAKE ADJUSTMENT / CHECK

Brakes should be adjusted at intervals as per the "Brake Maintenance Schedule" outlined in this section, when the brake shoes and drums have "seated", or as use and performance requires.

The brakes should be adjusted in the following manner:

1. Jack up trailer and secure on adequate capacity jack stands. This system contains a built in Jacking point under the arm. Check that the wheel and drum rotate freely.
2. Remove the cover from the adjusting slot on the bottom of the brake backing plate.
3. With an adjusting tool, rotate the star wheel of the adjust assembly to expand the brake shoes. Adjust the brake shoes out until the pressure of the linings against the drum locks the wheel against movement by hand.
4. Rotate the star wheel in the opposite direction 7-10 turns until the wheel turns freely with a slight lining drag.
5. Replace the adjusting hole cover and lower the wheel to the ground.
6. Repeat the above procedure for all brakes.

IMPORTANT: *Never crawl under your trailer unless it is securely resting on properly placed jack stands.*

Watch how to adjust trailer brakes on YouTube: [▶ CruisemasterClass - Ep 1](#)

BEDDING THE BRAKES (NEW BRAKES)

Before any synchronization adjustments are made, your trailer brakes should be bedded in by applying the brakes 20-30 times with approximately a 30 km/h decrease in speed, e.g. 60 km/h to 30 km/h. Allow ample time for brakes to cool between applications.

This allows the brake shoes and magnets to "wear-in" to the drum surfaces.

During this time, maintain a mid-low setting on your controller to avoid any shoe damage by rapid bedding.

There should be no sensation of the trailer 'jerking' or 'pushing' the tow vehicle. The trailer should not be braking the towing vehicle, as overheating of the brakes and premature wear may occur.

Stable brake temperature and torque may not be achieved until 500 - 1,000 Km's.

IMPORTANT: *To ensure safe brake performance and synchronisation, read the brake controller manufacturer's instructions completely before attempting any synchronisation procedure.*

IMPORTANT: *Before road testing make sure this it is safe to do so.*

USING A BRAKE CONTROLLER

Your trailer brakes are designed to work in synchronization with your tow vehicle brakes. Never use your tow vehicle or trailer brakes alone to stop the combined load. Electric brake controllers provide a modulation function that varies the voltage to the electric brakes with the pressure on the brake pedal or amount of deceleration of the tow vehicle.

Proper synchronization of tow vehicle to trailer braking can only be accomplished by road testing.

POWER REQUIREMENTS

Each brake will operate with a current draw of 3 amps, remembering a single axle set will draw 6 amps during service and a tandem will draw 12 amps. Wiring should be sized accordingly to ensure minimal voltage drop along the length of the trailer.

BRAKE SERVICE - CLEANING AND INSPECTION

Your trailer brakes must be inspected and serviced at yearly intervals or more often as use and performance requires. Magnets and shoes must be changed when they become worn or scored thereby preventing adequate vehicle braking.

Clean the backing plate, magnet arm, magnet and brake shoes. Make certain that all the parts removed are replaced in the same brake and drum assembly.

Inspect the magnet arm for any loose or worn parts. Check shoe return springs, hold down springs, and adjuster springs for stretch or deformation and replace if required. Before reassembling, apply a light film of Silver Grade Anti-Seize or similar grease, or anti-seize compound on the brake anchor pin, the actuating arm bushing and pin, and the areas on the backing plate that are in contact with the brake shoes and magnet lever arm. Apply a light film of grease on the actuating block mounted on the actuating arm.

IMPORTANT: Do not grease or oil on the brake linings, drums or magnets.

BRAKE SERVICE - MAGNETS AND DRUMS

Electric brakes are equipped with high quality electromagnets that are designed to provide the proper input force and friction characteristics. Magnets should be inspected and replaced if worn unevenly or abnormally. A straightedge should be used to check wear.

Even if wear is normal as indicated by your straightedge, the magnets should be replaced if any part of the magnet coil has become visible through the friction material facing of the magnet. It is also recommended that the drum surface be refaced when replacing magnets. Magnets should also be replaced in pairs – both sides of an axle. Use only genuine replacement parts when replacing your magnets.

We recommend the 10" drum internal diameter be no more than 256.3mm and the 12" drum be no more than 307.0mm. If the internal diameter exceeds this dimension in either case the brake drum should be changed immediately to ensure safe brake operation.

BRAKE SERVICE - SHOES AND LININGS

A simple visual inspection of your brake linings will tell if they are usable. Replacement is necessary if the lining is worn (to within 1.6mm or less), contaminated with grease or oil, or abnormally scored or gouged.

Hairline heat cracks are normal in bonded linings and should not be a cause for concern. It is important to replace both shoes on each brake and both brakes of the same axle. This is necessary to retain the "balance" of your brakes.

PARK BRAKE OPERATION

When using the park brake facility, a cable is attached to the designated lever arm on the outside of the backing plate then to the base of the handbrake so to operate the brakes without need for constant electricity supply.

PARK BRAKE CABLE ADJUSTMENT

The cable should be adjusted in such a way that when the handbrake is disengaged there is some slack in the cable to ensure the brakes will not be dragging during normal operation.

It is recommended to adjust this so that at the highest engaged position of the handbrake the attachment lever is vertical. A further check should be made with the suspension at both ends of its travel to ensure the brakes do not operate in the bump and rebound conditions.

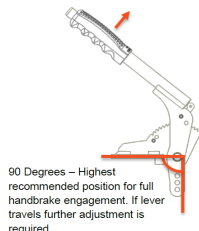

USE OF PARK BRAKE

Operation of the handbrake is the same as a standard mechanical vehicle handbrake. Simply pull the handle until the cable is tight and the handbrake locks in to the ratchet. In order to release the handbrake, pull the lever slightly and depress the handbrake button to make sure the pawl is free from the ratchet plate then return the lever to its resting position.

The following factors affect handbrake efficiency and should be considered when configuring your handbrake system.

- Wheel and tyre diameter
- Handbrake cable routing
- Brake condition or 'bedding in'
- Road surface
- Selected hole position in lever
- Pull force exerted on handbrake lever
- Brake type and size
- Angle of surface

Running Gear Safety & Maintenance (cont...)

Rev. 09-2025

Wheel Bearing Maintenance

NOTICE: It is imperative that trailer wheel bearings be repacked (re-greased) yearly, after periods of storage and/or every 3000 miles of travel to prolong life of hub and axle assemblies.

NOTICE: THIS IS CONSIDERED ROUTINE MAINTENANCE AND IS THE RESPONSIBILITY OF THE OWNER TO ENSURE IT IS DONE REGULARLY.

Tires

The following information is provided to make tire safety a regular part of your Imperial RV and tow vehicle maintenance routine.

Tire Maintenance

Well maintained tires improve steering, stopping, traction, and load-carrying capability of your tow vehicle and your Imperial. Under or over inflated tires, overloaded (over weight) trailers, un-balance load in the trailer and overloaded tow vehicles are a major cause of tire failure. To avoid flat tires and other types of tire failures, inspect tires before each trip, maintain proper tire pressure, observe tire's condition, keep your load balanced, the weight below your RV (GVWR & GAWR) and your tow vehicle load limits, and avoid hazardous road conditions.

Know Your Vehicle's Recommended Tire Pressure and Load Limits (GVWR & GAWR)

The tire information and trailer certification label contains information on tires and load limits.

These labels indicate the trailer frame's manufacturer's information including:

- Recommended tire size.
- Recommended tire inflation pressure.
- Gross Vehicle Weight Rating (GVWR - the maximum occupant and cargo weight a vehicle or trailer is designed to carry).
- Gross axle weight ratings (GAWR - the maximum weight each axle is designed to carry).

Understanding Tire Pressure and Load Limits

Tire inflation pressure is the amount of the air in the tire that provides it with load-carrying capacity and affects the overall performance of the tire and vehicle. The tire inflation pressure is a number that indicates the amount of air pressure, measured in pounds per square inch (psi) a tire requires to be properly inflated (this number is also expressed in kilo pascals (kpa) which is a metric measuring system used Internationally).

Vehicle manufacturers determine this number based on the vehicles' design load limit which is the greatest amount of weight a vehicle can safely carry and the vehicle's tire size. The proper tire pressure for your vehicle is referred to as the 'recommended cold inflation pressure'. Tire pressure should always be measured when the tire is 'cold' to get an accurate measurement. A cold tire is one that hasn't been driven on for at least 3 (three) hours. As you drive, your tires get warmer causing the air pressure within the tire to increase. Therefore, you cannot get an accurate measurement of tire pressure unless the tire is cold.

Checking Tire Pressure

INFLATE THE TIRES ON YOUR IMPERIAL TO 65PSI FOR ON-ROAD TOWING.

Because tires are designed to be used on more than one type of vehicle, tire manufacturers list the 'maximum permissible inflation pressure' on the sidewall of the tire. The number is the greatest amount of air pressure that should ever be put in the tire under normal driving conditions.

It is important to check your vehicle's tire pressure at least once a month for the following reasons:

- Tires lose air pressure over time.
- Tires can lose air suddenly if you drive over a pothole, drive on ruff surfaces or strike the curb.
- With radial tires it is not always possible to determine under inflation by visual inspection.

For your convenience, purchase a good quality tire pressure gauge to keep in your tow vehicle.

Preventing Tire Damage

Slow down if you have to go over a pothole, object in or a rough road.

Do not run over foreign objects in the roadway and try not to strike the curb when parking.

Tire Safety Checklist

- Check tire pressure regularly (at least once a month and before each use), including any spare.
- Inspect tires for uneven wear patterns on the tread, cracks, foreign objects, or other signs of wear or trauma.
- Remove bits of glass, stones or any other foreign objects wedged in the tread.
- Make sure your tire's valve stems have valve caps to keep dirt out of them.
- Check tire pressure before going on every trip and before each leg of your trip.
- Do not overload your vehicle or load your trailer unbalanced. Check the tire information placard for the maximum recommended load for the vehicle (see Loading and Balancing section of this manual).
- Remember that some of the weight of the loaded trailer is transferred to the towing vehicle.

Frame and Frame Maintenance

Periodic maintenance of the frame includes removing rust and touching up the paint (every 6 months). This will ensure your Imperial trailer lasts for years.

Proper Loading and Balancing of Trailer

FAILURE TO FOLLOW THESE INSTRUCTIONS MAY CAUSE SERIOUS BODILY INJURY OR DEATH, CAN CREATE UNSAFE DRIVING CONDITIONS, AND / OR CAUSE DAMAGE TO YOUR VEHICLE AND / OR YOUR IMPERIAL RV.

Determining the weight of a vehicle includes more than understanding the load limits of the tires. A weight certification label, located on the forward half of the road side of the unit, will indicate the gross axle weight (GAWR) and the gross vehicle weight (GVWR). This is the most weight the fully loaded vehicle can weigh. If there are multiple axles, the GAWR of each axle will be provided.

Look in your Yellow Pages or the internet for truck stops, gravel pits, storage companies or recycling facilities to find certified scales. Call in advance to determine if they offer public weighing service, their fees and hours of operation.

DO NOT OVERLOAD YOUR IMPERIAL RV. DO NOT assume that you can fill all the water and holding tanks and all storage areas and still be within the GVWR.

Running Gear Safety & Maintenance (cont...)

Rev. 09-2025

THERE IS A LIMIT TO HOW MUCH WEIGHT and WHERE THAT WEIGHT CAN BE PLACED IN YOUR RV AND STILL OPERATE IT SAFELY ON THE ROAD AND NOT DAMAGE THE TRAILER OR TOW VEHICLE.

You are towing a trailer, remember that some of the weight of the loaded trailer is transferred to the towing vehicle via the trailer's hitch (tongue weight of trailer). Proper loading & balancing of your RV is imperative to the safe operation of your tow vehicle!

WHEN ESTABLISHING THE CARGO CAPACITY, WEIGH YOUR EMPTY RV WITH THE FRESH WATER AND WASTE WATER HOLDING TANKS AS EMPTY AS POSSIBLE, LP TANKS FULL, AND NOTHING IN THE TRAILER (DO NOT PUT YOUR PERSONAL BELONGINGS OR ALLOW ANYONE TO BE IN YOUR EMPTY RV WHEN WEIGHING THE UNIT).

CARGO CAN BE ADDED TO YOUR RV UP TO THE MAXIMUM WEIGHT SPECIFIED ON THE WEIGHT LABEL. THE COMBINED WEIGHT OF THE YOUR EMPTY IMPERIAL RV AND ITS' CARGO CANNOT EXCEED THE STATED GVWR OR THE GAWR

NOTICE: Your tow vehicle and tow vehicles hitch also have a maximum towing capacity and a maximum tongue weight capacity. Be sure that you do not exceed these weights!

NEVER EXCEED THE GVWR, FOR YOUR TOW VEHICLE, YOUR LOADED IMPERIAL RV'S FRAME, AXLE(S), WHEELS OR TIRE MANUFACTURER'S RECOMMENDATIONS FOR MAX LOAD WEIGHT (GVWR).

GAWR (Gross Axle Weight) PLUS (+) Tongue Weight EQUALS (=) GVWR (Gross Vehicle Weight)

GAWR - (Gross Axle Weight Rating) is the allowable weight, including cargo that can be safely supported by each axle.

GVWR - (Gross Vehicle Weight Rating) is the GAWR + Tongue Weight and is the maximum allowable weight of the fully loaded trailer.

TONGUE WEIGHT

Tongue Weight is the weight of the tongue as it bears down on the hitch of the towing vehicle. It is important to note that the tongue weight will be added to the rear axle weight of the tow vehicle and will reduce the front axle weight of the tow vehicle.

- Tongue weight should be determined with the RV fully loaded as it would be for travel.
- Tongue weight will change when you load and how you load your RV.
- Tongue and Trailer weight and loading will directly affect the handling of your tow vehicle.

NOTICE: Excessive, Not Enough or Negative tongue weight can cause dangerous adverse conditions in the tow vehicle, including, but not limited to, over or negative weight for tow vehicles rear axle, underweight for tow vehicles front axle, and could lead to unstable driving conditions of the tow vehicle MAKING IT DANGEROUS TO DRIVE THE TOW VEHICLE AND TOW YOUR RV!

UVW - (Unloaded Vehicle Weight) is the weight of the trailer as manufactured at the factory. It includes the complete weight of the trailer axle(s), tires and the tongue. If applicable, it also includes full fluids including LP tanks, and hydraulic pump fluids. UVW does not include the weight of full fresh water tanks, full holding tanks or whatever personal items you put inside.

CCC - (Cargo Carrying Capacity) is equal to GVWR minus the UVW. CCC is the weight of cargo you can safely put in your RV. Cargo weight includes fresh water weight and anything you put inside or on the RV.

The weight of fully filled propane containers is considered part of the weight of your RV before it is loaded with cargo and is NOT considered part of the cargo load (CCC) Water is a cargo weight (about 8.34 lbs per gallon). If there is a 15 gallon fresh water storage tank, when this tank is full it weighs over 125 pounds. If needed, water and your waste water holding tank can be emptied to keep the total amount of cargo added to the trailer within the limits of the GVWR and may lower your Imperial's tongue weight. Understanding this flexibility allow you to make choices that fit your travel and camping needs.

Note: Before filling the fresh water tank, empty the Waste Water Holding tank. Most campgrounds, RV centers and some truck stops supply dump stations for this purpose. Doing this will provide more cargo capacity.

Note: If you find that you have exceeded the GVWR of your Imperial, you will have to remove items until you are within the specified limits. After you have determined how much weight you can safely carry, make a list and keep it for future reference. This will limit the amount of time it takes you to get ready for the road.

Trailer Load Limits

After you have determined what cargo weight (CCC) makes up the allowable GVWR, you can then load your personal items into your RV without exceeding the GVWR, GAWR or Tongue Weight.

When loading your RV, remember to distribute the weight evenly so you get the proper amount of weight on the axles and hitch.

Remember to also consider the weight of items you may purchase on your trip.

Do not place heavy items in the overhead cabinets. They could sift and fall during travel. Heavy items should be stored close to the floor in the center of the unit.

Luggage and similar cargo stored inside your RV must be secured to prevent possible damage if it should become necessary to make a sudden stop or in case of an accident.

Store emergency items such as flashlights, flares, tools, electrical cords and first-aid kits in an easily accessible storage compartment, taking care to keep those items in a waterproof container to keep them clean and dry.

Empty your Fresh Water and Waste Water Holding tanks before beginning each leg of your trip. Carry only as much water as needed for travel use or to balance the load.

Weight Distribution

Weights of stored items will vary greatly and will affect total weight of your RV. Always weigh your RV at a certified weight station equipped with platform scales.

Trailer and Tow Vehicle Hitch

Refer to YOUR vehicle's and YOUR vehicle hitch's manufacture's information for complete information on usage, care and manufacturer's warranty.

Running Gear Safety & Maintenance (cont...)

Rev. 09-2025

Tow Vehicle Hitch

It is very important to choose a tow vehicle hitch designed for your particular tow vehicle and have it properly installed. Choosing the correct hitch for use with your tow vehicle and Imperial RV will enhance the stability and maneuverability of your Imperial RV and tow vehicle combination. Always make sure the hitch has the correct size hitch ball (see hitch on trailer for correct size).

Safety Tow Chains

On an Imperial RV and any trailer being towed, the safety chains should always be connected by crossing them under the trailer tongue. The right chain attaches to the left side of the tow vehicles hitch and the left chain attaches to the right side. This will form a "cradle" that could "catch" the hitch coupler should it come loose from the tow vehicle. The end connectors should always be connected to the hitch base plate or another location specifically provided for this purpose on your tow vehicle's hitch. If the chains are too long, simply twist them to make them shorter so they do not drag on the ground.

NOTE: NEVER attach safety chains by looping around Hitch Coupler (or receiver).

NOTE: YOU MUST LOWER THE TONGUE'S HITCH LATCH AND INSERT THE SAFETY PIN INTO THE HOLE BEFORE MOVING YOUR TRAILER.

NOTE: AT NO TIME SHOULD THE WEIGHT OF THE FULLY LOADED UNIT EXCEED THE TOW VEHICLES' MAXIMUM WEIGHT TOW RATING.

Leveling Your Imperial RV

NOTICE: Leveling your RV is necessary for the correct operation of the gravity flow waste water drains, sink operation, the cooling system of the refrigerator, the A/C system, and proper water drainage of the windows, doors roof and roof gutters. Choose a site that is as level as possible. Be sure the ground is not soft and will support the weight of your RV. Before unhitching you Imperial from the tow vehicle, level you RV from side to side with the appropriate stacks and lengths of wood under the tires. Use jacks to fine-tune leveling without fully lifting tires off the ground.

Electrical

Rev. 09-2025

Exterior Trailer Running Lights

Before each trip, check the operation of your RV's exterior running, clearance, turn signal and brake lights to be sure they are working correctly. Replace any cracked, broken or missing light covers to avoid moisture infiltration and possible damage to the electrical system.

12V Electric Brakes, Electric Brake Break Away

Your Imperial trailer (if equipped with electric brakes) MUST have a 12V power supply connected to the trailer brake break away system for them to work in emergencies.

The electrical power for your RV is a dual source system operating with both 110V AC and/or 12V DC.

There are up to 3 electrical systems on your RV.

1. 12V Power from tow vehicle for running lights and electric brakes.
2. 12V plug-ins, lighting, components, and charging system via the 110V converter.
3. 110V converter for 110V GFCI plug-in, 110V lighting, 12V components via the converter.

Connecting to an Outside Power Source

Never use a two wire extension cord, a "cheater" adapter with the ground pin removed, or put a lower amperage plug on your power cord in place of the molded plug.

Connecting power cord to a non-grounded or improperly grounded source can result in a possibly fatal electric shock.

Nelson Industries, Inc. CAN NOT BE HELD RESPONSIBLE SHOULD DAMAGE, INJURY OR DEATH RESULT FROM FAILURE TO CONNECT THE POWER CORD TO A PROPERLY GROUNDED POWER SOURCE.

30 amp AC Power Cord Adapter

A 30 amp power cord adapter is provided to connect your Imperial RV to a grounded power source. You will need to purchase a 30 amp power cord the length of your choice. The electric utility service connection is located on the driver's side, forward of the wheel well. The 110V power may be provided by either connecting your RV to an outside power source when parked, or by use of a generator. When the 110V system is operational, power also passes through the electrical power converter, allowing the full use of all 12V functions in your Imperial.

Battery Charger Operation on 110V

Batteries are recharged by the electrical power converter only when the RV is attached to an outside 110V power source, or a generator. Electrical Converter Operation, Breakers and Fuses Refer to the electrical converter manufacturer's information in your Imperial Owner's Packet for complete information on usage, care and manufacturer's warranty.

Electrical Converter Operation

The electrical power converter provided in your RV is a dual system, operating with 110VAC and/or 12V DC. The 110V power may be provided by either connecting your Imperial to an outside power source when parked, or by use of 110V generator. When the 110V system is operational, power also passes through a converter, allowing the full use of all 12V functions in your Imperial.

110V functions in your Imperial include: Electrical Converter, 110V outlets and 110V lights, refrigerator, roof mounted air conditioner(s), TV, microwave oven, and refrigerator. All other electrical functions in your Imperial are supplied with 12V power.

12V Power Converter

When it is not possible to access 110V power, the 12V system functions are supplied by the battery. The battery is recharged by the power converter when your Imperial is attached to an outside 110V power source or to 110V generator.

The converter is also used to switch 110V electricity from an external power supply or generator to 12V electricity. If the converter does not have a 110V supply connected it automatically switches the batteries into the electrical circuit to 12V power. When reconnected to a 110V power source, it will automatically switch back to 110V power.

Under normal conditions, the converter requires no maintenance. The converter will run warm, which is normal. If, however, it gets too hot, it will turn itself off. After it cools, it will come back on. In most cases, shut down occurs due to poor ventilation. A slight hum during operation is also normal for the converter. If you have no 12V power and no hum, check to see if 110V power to the converter has been interrupted.

110V GFCI (Ground Fault Circuit Interrupter)

NOTE: THE GFCI DOES NOT PROTECT ANY CIRCUIT OTHER THAN THE ONE TO WHICH IT IS CONNECTED. EVEN WITH GFCI PROTECTION, PERSONS WITH SEVERE HEART OR OTHER HEALTH PROBLEMS MAY STILL BE SERIOUSLY AFFECTED BY AN ELECTRICAL SHOCK. THE GFCI OUTLET IS NOT A SUBSTITUTE FOR GOOD ELECTRICAL SAFETY. IT DOES NOT PROTECT AGAINST CONTACT OF THE HOT AND NEUTRAL WIRE AT THE SAME TIME.

The 110V outlets are equipped with a protective circuit interrupter. The ground fault circuit interrupter (GFCI), is designed to break the flow of current to the protected outlet when an imbalance of current is detected. Imbalances include electrical leakage in an appliance such as a shaver or hair dryer that have developed a weak spot in electrical insulation. The possibility of electrocution exists when using a faulty appliance, while you are at the same time in contact with an electrical ground such as water, plumbing or the earth.

GFCI outlets are designed to have additional outlets connected through them. When wired correctly, the additional outlets (called the load on the GFCI outlet) are also protected by the GFCI outlet.

If an imbalance is detected, the GFCI will trip and shut off power to the GFCI outlet and any additional (load) outlets properly wired to the GFCI outlet. Even with GFCI protection, the electrical shock will still be felt, but to a lesser degree. It also does not protect against short circuits or system overloads. The 110V circuit breakers, (see next section on 110V circuit breakers) in the converter panel which supply power to the GFCI, will trip to protect against short circuits or system overloads.

The GRCI receptacle should be tested initially when the RV is purchased and at least monthly thereafter.

To test the GFCI Circuit, use the following procedure:

1. Make sure power to the circuit is ON.
2. Push the test button on the GFCI outlet.
3. The red reset button should pop out.
4. All power should be interrupted to outlets protected by the GFCI.

Testing of the GFCI outlet does not test the correct wiring of or any additional 110V outlets connected to the GFCI outlet. A special 110V GFCI circuit tester is available from your local hardware store that will enable you to test these additional outlets. You can also verify Load outlets connected to GFCI outlet by plugging in a light at these outlets, and pushing in the red reset button. If the button does not pop out after pushing the test button, or GFCI circuit continues to trip, immediately turn off power at the circuit breaker panel and have a qualified electrician service it.

NOTICE: THE GFCI OUTLET DOES NOT PROTECT ANY CIRCUIT OTHER THAN THE ONE(S) TO WHICH ARE PROPERLY CONNECTED TO THE GFCI OUTLET VIA THE LOAD BRANCH OF THE GFCI OUTLET.

110V Circuit Breakers

The 110V electrical system on your RV is protected by circuit breakers. These circuit breakers automatically trip if the circuit load is too heavy, or a short circuit occurs. If a circuit breaker has been tripped, do not reset the breaker until the cause of the problem is identified and corrected. Once the cause of the problem has been corrected, turn the tripped 110V circuit breaker to the full off position and then turn it to the full on position.

12V DC and 12V DC Fuses

A 12V DC distribution panel is located in the electrical converter next to the 110V circuit breakers. The panel contains circuits with replaceable fuses for protection of 12V lines, 12V outlets and 12V appliances. If any line is loaded beyond the capacity of its fuse, the fuse will blow. A portion of the 12V load on the line must be turned off to reduce the total load on the line to a level below the capacity of the fuse before replacing the fuse and re-energizing the circuit. Replace the fuse with only the same size amperage fuse. If this reduction of load on the line does not stop the blowing of the fuses, there may be a short somewhere along that 12V line, or at a 12V component plugged into the line. Check the 12V line and any components plugged into that line. Locate the short and take necessary steps to repair it. If you cannot locate the problem, contact your Imperial dealer or call a qualified electrician.

Power Inverter

Make sure inverter is turned off when not in use. Inverter is calibrated and optimized to factory settings. The password for changing settings in the inverter is: 1234 (GoPower only). Consult the GoPower Operations Manual for info before modifying current set-up!

Battery Installation, Operation & Charging

Safety

Your unit comes installed with Expcion360 Group 27 LiFePO4 lithium batteries with SmartTalk™ and VHCTM. Expcion360 lithium batteries use lithium iron phosphate (LiFePO4/LFP) chemistry, which is the best choice for RV, marine, and off-grid power storage applications because of its high degree of safety and long cycle life.

Battery Storage

Most users will see their batteries in storage more often than active daily use. To prolong the battery life during periods of storage of one month or longer, please follow storage instructions.

Properly storing the battery system between 50% and 80% state-of-charge (SoC) will prolong the battery. Check the SoC on the battery system monitor or Expcion360 App.

Before storing, turn off the battery system disconnect switch, and turn off the battery system by pressing the POWER switch on each battery for 5 seconds. Charge the battery system to full before using it after storage.

Please follow the guidelines below for lengths of storage time.

- | | |
|------------------|------------------------|
| 1 month: | 13.4Vdc, -4°F to 113°F |
| 3 months: | 13.4Vdc, 32°F to 77°F |

Charge each battery every 3 to 6 months. See battery user manual for complete safety, storage, and charging information.

IF BATTERIES ARE DISCHARGED TO 0% SoC...

Immediately charge the battery system to 80% SoC and confirm that the battery system disconnect switch is disconnected. All batteries using LiFePO4 chemistry will be permanently damaged if discharged to 0% SoC and left for over one week. The warranty excludes coverage for such damage due to the end-user's neglect of the batteries.

Battery Installation, Operation & Charging (cont...)

Rev. 09-2025

NOTICE: Read the Expon User Manual for detailed installation, care & troubleshooting information. When removing a battery, disconnect the ground battery clamp first. When installing a battery, always connect the grounded battery clamp last. When a battery needs to be replaced, make sure to replace it with a battery of the same specification as the original equipment. Consult your Imperial Dealer for advice on battery replacement.

BATTERY SAFETY

DO NOT: DROP THE BATTERY

DO NOT: OPEN THE BATTERY

DO NOT: SHORT CIRCUIT THE BATTERY

DO NOT: SUBMERGE THE BATTERY IN WATER

DO NOT: USE THE BATTERY AS A STARTER BATTERY

DO NOT: USE BATTERIES OF DIFFERENT AGES AND/OR CAPACITIES

DO NOT: CONNECT THE BATTERIES IN SERIES

DO NOT: CONNECT MORE THAN 4 BATTERIES IN ONE PARALLEL STRING

DO NOT: ATTEMPT TO REPAIR THE BATTERY IF IT MALFUNCTIONS

DO NOT: CHARGE THE BATTERY ABOVE 14.6V DC

DO NOT: CHARGE THE BATTERY AT OR BELOW 32°F OR 0°C

DO NOT: CHARGE THE BATTERY ABOVE ITS MAXIMUM CHARGE RATE

DO NOT: DISCHARGE THE BATTERY BELOW 10.5V DC

DO NOT: DISCHARGE THE BATTERY AT OR BELOW -4°F OR -20°C

DO NOT: DISCHARGE THE BATTERY ABOVE ITS MAXIMUM DISCHARGE RATE

DO NOT: LEAVE THE BATTERY CONNECTED WHEN IN STORAGE

DO NOT: LEAVE THE BATTERY FULLY DISCHARGED FOR AN EXTENDED PERIOD

Battery Charging

See battery user manual for complete charging information.

Fire Safety

Rev. 09-2025

Smoke Detector Operation

Refer to the Smoke Detector manufacturer's information in your owner's packet for complete information on usage, care and warranty.

NOTICE: There are no 12V or 110V electrical wires to the smoke detector. The smoke detector is operated only by a single 9V battery. Be sure to change the battery every 3 months.

NOTICE: Never ignore alarms on safety devices. If the alarm sounds and you are not absolutely certain of the source, get everyone out immediately.

CO/LP Detector

Your RV is equipped with a dual purpose CO/LP detector.

CO portion of the Detector

The carbon monoxide detector is designed to detect carbon monoxide from any source of combustion. It is NOT designed to detect smoke, fire or any other gases. This detector is hard wired to the RV's 12V converter system and will operate as long as there is 110V to the converter or as long as the 12V battery is connected and has a charge. Test alarm each week while in use and before beginning a trip. Press the "TEST" button. If the alarm fails to sound replace the unit immediately. DO NOT attempt to repair the detector.

LP portion of the Detector

It sense propane gas in the air, not smoke or fire or other gases. It detects the presence of propane gas at the sensor, explosive gas may be present in other areas. Test you LP detector weekly. DO NOT attempt to repair the detector. If it fails, replace the unit immediately.

In the event of an LP detector alarm:

If the detector senses the presence of LP gas, the light will turn from green to red, accompanied by an audible alarm. Immediately evacuate all occupants from the RV. Extinguish any open flames, pilot lights and all smoking material. DO NOT touch any electrical switches. Shut off the gas supply at the tank. Open doors and windows to ventilate. DO NOT USE POWER VENTS. The alarm will continue to sound as long as LP gas is detected or until turned off.

DO NOT bring or store LP gas cylinders, gasoline or other flammable liquids inside the vehicle. A fire or explosion could result.

LP gas regulators must always be installed with the regular vent facing downward. Regulators that are not in compartments have been equipped with a protective cover. Be sure the regulator cover is kept in place to minimize vent blockage that could result in excessive gas pressure causing fire or explosion.

DO NOT rely upon being able to smell LP gas leaks as the odor may not be sufficiently strong enough to detect.

If you detect a sulfur or 'rotten egg' odor, DO NOT, turn on any appliances. Shut off all operating appliances. Extinguish any open flames, including cigarettes. DO NOT touch any electrical switches. Open windows and doors and exit the vehicle. Shut off the gas supply at the LP tank (or source).

Fire Extinguisher Operation

Refer to the fire extinguisher manufacturer's information located directly on the Fire Extinguisher for complete information on usage and care.

NOTICE: The fire extinguisher provided with this RV is a chemical type suitable for extinguishing small fires. Extinguishers are designed to put out a fire in its initial stage, not if it is blazing out of control

IF A FIRE CANNOT BE APPROACHED WITHIN 10' DO NOT ATTEMPT TO PUT IT OUT, IMMEDIATELY EVACUATE THE RV AND CALL 911.

WARNING: LP (Propane) Gas regulators must always be installed with the regulator vent facing downward. Regulators that are not in compartments have been equipped with a protective cover. Owners must make sure that the regulator vent faces downward and that the cover is kept in place to minimize vent blockage that could result in excessive propane pressure causing fire or explosion.

LP System

The liquid petroleum (LP) gas system in your recreational vehicle furnishes the fuel for heating and hot water. It is a clean, efficient and safe form of energy ONLY when proper handling and safety precautions are observed. The gas is stored with extreme pressure in the tank(s), with space in the tank to allow for expansion into vapor. This vapor is reduced in pressure by passing through a regulator. The regulator reduces the pressure in a two-step process which assures consistent pressure for use, regardless of outside temperatures, weather or altitude.

LP Regulator

LP gas is under high pressure in the tank. The purpose of the regulator is to reduce the pressure inside the tank to allow operation at a safe pressure for use.

LP gas regulator most commonly used on LP tanks are: 18 PSI (pressure per square inch) single stage LP gas regulator, most commonly used on single tanks. 30 PSI (pressure per square inch) two stage LP gas regulator, most commonly used on dual tanks.

NOTE: Always keep your regulator attached to a tank to prevent dirt from getting into the regulator and tank connectors.

DO NOT adjust or repair the regulator. Regulators are preset at the factory to certain specifications and should only be adjusted by a qualified propane service technician. To avoid potential problems, have your LP gas system checked at least once a year by an authorized service center and after each extended trip. Be sure to keep the service valve on an empty tank closed where you suspect a leak.

Regulator Cold Weather Factors

As outside temperatures drop, the BTU value of the LP gas is lessened. The colder liquid LP in the tank(s) require heat from the surrounding air to vaporize. The lowering of BTU value can significantly affect the performance of the system. Keeping your LP tanks as full as possible in cold weather and reviewing the BTU/hr rating plates on LP appliances will help ensure proper LP management.

Regulator Freeze-Up

The term 'regulator freeze-up' is a misleading one. Regulators and LP gas do not freeze. However, the moisture that can be contained in the gas will freeze as the gas expands and cools passing through the regulator. This freezing of the moisture in the gas can build up and partially or totally block the passage of the gas through the regulator. Freezing can also occur when outside temperatures are low enough to contribute to the freezing of the moisture in the gas.

The source of the moisture is varied. It can occur at the refinery or gas bulk plant, in the cars used to transport the gas, or even within your own LP tanks. Moisture in an LP tank can occur when a tank service valve is left open, allowing moist air to enter and become trapped. A two-stage regulator helps reduce the possibility of freeze-up because of its larger orifice size and that heat is being transferred through the walls of two regulators instead of only one.

NOTICE: DO NOT overfill the LP tank.

Tips to help prevent regulator freeze-up

- Make sure your LP tank is free of moisture before refilling.
- If freezing occurs, have your LP dealer purge the LP tank before refilling.
- Check with your dealer to determine what deicing agent is approved to add to the LP tank.
- Keep the regulator connected to a tank and the tank(s) and regulator covered at all times.

NOTE: If freeze-up does occur, shut the LP off at the tank(s). A frozen regulator may permit LP gas to flow at high pressure, resulting in leaks at appliances in the gas lines. NEVER ATTEMPT TO THAW WITH AN OPEN FLAME! A small wattage light bulb can sometimes be useful to provide heat and air in the thawing process. Once the line is thawed, be sure to take the proper steps to prevent a recurrence. Have the system checked by your RV dealer.

LP Pigtail

The LP pigtail is the hose that connects to the LP regulator on the tank through which the LP fuel flows. This safety feature is generally recognized by the large green nut that attaches to the outside of the valve on the regulator. This will limit excessive gas flow and prevents gas from flowing unless the connection is tight.

LP Fuel Systems, Containers, LP Component Equipment Refer to each LP use component manufacturer's information in your owner's packet for complete information on usage, care and Manufacturer's warranty.

Propane (LP) Containers

** WARNING: IF YOU SMELL PROPANE **

- Extinguish any open flames, pilot lights, and all smoking materials.
- Do not touch electrical switches.
- Shut off the propane supply at the container valve or propane supply connection.
- Open doors and other vent openings.
- Leave the area until odor clears.
- Have the propane system checked and leakage source corrected before using again.

Furnace & Thermostat

Rev. 09-2025

Furnace & Thermostat Operation

Refer to the furnaces manufacturer's information in your owner's packet for complete information on usage, care and manufacturer's warranty.

NOTE: Before operating the furnace check the location of the furnace vent to be sure it will not be blocked by the opening of any door on the RV (or by exterior items such as bushes, or trees).

ALWAYS open a window slightly to allow a little fresh air into your RV. The furnace is ignited simply by moving the thermostat's temperature setting indicator to the right and set it at a temperature above the current room temperature. Parking your Imperial so that the wind hits the front or back will assist in ensuring the furnaces (and refrigerator's) air intake and exhaust vent are not being affected by the wind.

Thermostat Operation

Many factors influence the temperature inside your RV. There are several things you can do to help manage the inside temperature and keep your furnace operating in the most extreme conditions. Keep doors, vents and windows (other than your fresh air window you opened before starting the furnace) closed as much as possible. Setting and leaving the thermostat at a temperature setting will allow the device to detect changes in temperature and operate efficiently. If you lower the temperature setting at night or when leaving, when you return simply reset the thermostat to the desired temperature. It is recommended to set the thermostat at a comfortable temperature and leave it.

Tips to assure continued safe operation of the furnace:

- Inspect furnace venting to ensure it is free of obstruction and does not have soot build up. Soot build up may indicate the furnace is not working properly and is in need of technical maintenance.
- Periodically have the main burner flame observe by an authorized technician to ensure it is burning with a hard blue flame. If the flame appears yellow or 'lazy', shut the furnace down. The burner may need to be cleaned or replaced.
- Keep the furnace intake grill area clear of any combustible materials, gasoline or other flammable vapor and liquids.

To avoid over-stressing your furnace:

- Check to be sure there are no gaps in windows or doors that would allow loss of heat other than the window you have chosen to provide fresh air into your RV
- Park the RV so the front or rear of the unit takes the brunt of wind force.
- Have your furnace checked to ensure it is operating at its highest capacity.
- Keep all vents free of obstruction.

NOTE: Whether using the HEATING or the COOLING, condensation is always an issue. Keeping your RV at a constant temperature helps keep condensation at a minimum. For more information on the effects of condensation refer the Condensation portion of in this manual.

Troubleshooting Furnace

If you are having problems with your furnace, there are a few things to check to ensure that the furnace will work flawlessly throughout the season.

- Read the manufacturer's manual and follow the manufacturer's operation and maintenance procedures.
- Make sure that your battery is fully charged and holds a good charge. Voltage to the furnace should be between 10.5 and 13.5 VDC during operation with the interior lights and other electrical components ON or OFF. When you are operating your Imperial RV on battery power only, you can deplete the battery to the point there is not enough voltage to operate the furnace fan and the furnace will shut down.
- Check the fuses and breakers in your converter to ensure nothing is tripped or a fuse has not blown.
- Make sure your LP tank has sufficient amount of gas, and if it is a new tank, be sure that the tank was purged when the first initial fill was done. A nice warm furnace is great when the outside temperature gets cold, unfortunately though, cold is an enemy of LP gas (see preceding LP section in this manual). The BTU capacity of LP gas decreases as the outside temperature gets colder. Based on how full the LP tanks are, the ambient temperature outside and how many BTU's the furnace is, there may not be enough gas to sustain ignition on the furnace. See chart below on BTU vaporization capacity of a 30 lb LP Tank.

% Full	20 F	0 F	-10 F
60%	50,400	25,200	11,900
50%	45,360	22,680	11,340
40%	40,320	20,160	10,640
30%	35,280	17,640	10,220
20%	30,240	15,120	7,560

- Check all vents, interior and exterior, make sure they are free from any obstruction to the air flow. This will overheat the furnace and put it into a lockout mode (refer to Furnace Manufacturer's Manual).
- If you continue to have problems with your furnace, have the system checked by your Imperial Dealer, a qualified LP gas service technician using proper equipment or an authorized RV center.

WARNING: At any time that you need to look at your furnace to try to figure out what is wrong with it, do not loosen or unhook any gas line fittings. This may cause gas to leak into your RV.

A/C Operation and Maintenance

Refer to the A/C Manufacturer's information in your owner's packet for complete information on usage, care and Manufacturer's warranty.

Cooling tips:

- Park the RV in a shaded area whenever possible.
- Use window shades (blinds or curtains) and consider buying a door window cover, to help keep the heat and sun out and the cold air in.
- Keep windows and doors shut and minimize usage.
- Avoid the use of heat producing appliances.

Starting the air conditioner in the morning and giving it a head start on the expected high outdoor ambient temperature will greatly improve its ability to maintain the desired indoor temperature.

NOTE: Whether using the HEATING or the COOLING, condensation is always an issue. Keeping your Imperial at a constant temperature helps keep condensation at a minimum. For more information on the effects of condensation, refer the condensation portion of in this manual.

NOTE: ALWAYS TURN OFF ALL ELECTRICAL APPLIANCES BEFORE DISCONNECTING THE RV FROM ITS' 110 VOLT POWER SOURCE.

NOTE: IF YOU COVER THE OUTSIDE PORTION OF YOUR AIR CONDITIONER DURING PERIODS OF STORAGE, BE SURE TO REMOVE PROTECTIVE COVER BEFORE REUSING.

We, at Nelson Industries, Inc., are an OEM only. We are not a service center for any of the components that are installed in your unit. For any assistance on issues that may come up, please contact your dealer or the manufacturer of the A/C (their contact information can be found in their manual).

LP Cooktop Operation

Rev. 09-2025

Refer to the Cooktop Manufacturer's information in your Imperial Owner's Packet for complete information on usage, care and Manufacturer's warranty.

Cooktop Operation

Your Imperial uses a LP(gas) cooktop. This unit operates on the trailer's LP system. Check your LP tank level before every trip. Open valve on LP tank slowly to turn on LP supply to your cooktop and furnace. When done cooking, make sure to turn all knobs to the "off" position to prevent damage or fire. We recommend closing the valve on your LP tank prior to travel.

Water System

Rev. 09-2025

NOTE: Your Imperial is equipped with 60gal of fresh water capacity as well as a 60gal grey water holding tank. You may also hook up your Imperial to a pressurized water supply if you are staying at a campground that provides water connection. See the Nautilus P4 User Manual for information on how to properly connect to your specific water supply as well as sanitize and winterize your water system.

Nautilus P4 system allows you to perform the following functions on your Imperial:

1. Power fill your fresh water tank for remote or dry camping
2. Use your pump to supply water to fixtures from fresh water tank
3. Use your pump to siphon fill or sanitize your fresh water tank from a bucket
4. Connect to city water at the camping site to supply water to fixtures
5. Winterize your plumbing lines and fixtures
6. Bypass hot water heater when winterizing to avoid water heater damage
7. Rinse off items outside unit with a hot/cold faucet

Maintenance

Rev. 09-2025

Preventative maintenance will pay for itself many times over by catching or preventing problems before they occur. Many repair costs are greatly increased by ignoring preventative maintenance procedures.

Keep good records of maintenance performed and be sure to follow all Owner Obligations and Manufacturer required maintenance as required.

Periodic maintenance and cleaning of your Imperial RV is necessary to retain the dependability, safety and appearance that will provide you with many miles of trouble free operation as well as protecting your investment.

It is also important to note that operating conditions will affect periodic maintenance service intervals. If you are towing or using your Imperial in extreme conditions such as heavy dust, continuous short trips, or start and stop heavy traffic, snow, rain and ice, means that the length of time between service appointments may have to be changed. Discuss a service interval timetable with your Imperial Dealer or trusted RV service center of your choice.

Ignoring small problems and issues will only allow them to become larger problems and possibly voiding your warranty due to neglect, misuse or abuse. If left unattended, small problems may also begin to affect other parts and systems of your RV.

Condensation

NOTICE: Condensation on a window is not a warrantable issue.

NOTICE: DAMAGE CAUSED BY MOLD OR MILDEW IS A MAINTENANCE ISSUE AND IS NOT WARRANTABLE.

Condensation is the change of water from its gaseous form (water vapor) into liquid water. Just as moisture collects on the outside of a glass of cold water during humid weather, moisture can condense on the inside surfaces of your camper. This condition is increased due to the small volume of space and the airtight construction of your Imperial RV.

Condensation and moisture can collect on inside surfaces during cold weather when inside humidity is high. While your Imperial is in use, multiple occupants can vaporize up to three gallons of water daily through daily living.

Mold occurs when condensation is left for prolonged periods of time and is extremely difficult to kill. Controlling condensation inside your unit is the best way to avoid mold and dampness issues, both of which can cause damage to your unit and/or its' contents.

Condensation can infiltrate the insulation, motors, working parts of appliances or plumbing connectors, just to name a few. Even though you may not see condensation, it may be inside the walls, cupboards or under the floor so it is best to watch for indications of too much humidity at take every precaution to avoid it from occurring. Generally, an area that is dark, warm, and where moisture can accumulate, is a potential breeding ground for mold.

It is especially important to air it out your RV when storing it or if you do not anticipate using it for an extended period of time. Empty the refrigerator and freezer, clean and dry it completely. Dry the inside of the sinks, shower and shower head.

Check for any leaks at the kitchen sink, toilet and bathroom sink. Check your unit periodically to ensure there is no condensation forming on the windows, which would indicate there is too much moisture in your unit.

If you see signs of too much moisture, take the necessary steps to remove the moisture to prevent possible damage to the contents or your Imperial itself. Rust on pipes, plumbing connectors or other parts of heating, plumbing or air conditioning equipment is also a sign of too much humidity.

NOTICE: REMEMBER THAT MOLD IS A MAINTENANCE ISSUE AND AS THE OWNER, PROPER MAINTENANCE OF YOUR IMPERIAL IS YOUR RESPONSIBILITY. CONTROLLING HUMIDITY INSIDE YOUR IMPERIAL WILL HELP TO PREVENT DAMAGE WHICH MAY OCCUR DUE TO NEGLECT.

Prolonged Occupancy

Your Imperial RV was designed for recreational use and short-term occupancy. If you expect to occupy your Imperial for an extended period of time, be prepared to deal with condensation and the humid conditions that may be encountered.

Frame, Extrusions and Aluminum Surfaces

Check the condition of the frame regularly. Keep it clean and repaint as necessary, to help avoid rust. It is especially important to keep underbody components clean when driving the recreational vehicle in the winter in areas where road salts are used.

To help avoid surface pitting, clean all extrusions when waxing your Imperial's siding. Special aluminum cleaners are available to restore the original luster to painted aluminum surfaces. Be sure to follow the instructions for use as outlined on the product package.

Roof

Inspection of roof components at least twice a year is very important to make sure seams, seals and caulking are not cracked or worn. Proper maintenance of seals and caulking are necessary to keep moisture from entering and causing severe damage, rot, mold or mildew. If you encounter dry, cracked or weathered seals or caulk, replace seals or re-caulk as necessary. Check with your Imperial dealer for the type of caulking required for your Imperial's roof and correct methods of resealing or re-caulking. A mild household soap solution and a soft brush can be used to clean roof.

Siding

Our siding finishes are the same as fiberglass gelcoat marine finishes. Any finish will deteriorate with time. Dulling and fading can be increased by exposure to extreme sunlight, air pollutants and excessive moisture. Regular washing will help prevent this from occurring.

NOTE: Physical damage to siding or roof should be addressed immediately to avoid moisture entering through breaks and causing problems with interior walls and components. Cover damaged areas in the siding or roof with plastic and sealing the edges with tape until proper repairs can be made.

Seals and Adhesives

It is important to maintain the seals and adhesives to prevent moisture from entering and destroying your unit's components. When washing your RV, inspect the seals for signs of drying out and wear. Be aware that weather and road vibration will have an effect on seals, causing them to dry, crack or separate.

Windows and Doors

Check the seals around the windows and door(s) regularly, to make sure sealant is present and completely adhered. Reseal or replace and reseal if sealant repair is necessary. If you are unsure about the correct methods, check with your Imperial Dealer.

Adjust and lubricate latches and moving parts annually, to ensure windows remain operative. Also check the condition and operation of door locks, adjusting and lubricating as necessary. If you are unsure about the correct methods of lubrication and adjustment, check with your Imperial Dealer.

Vinyl seals around windows and doors should be cleaned regularly and kept flexible by using a silicone spray or lubricant. Be sure to follow the directions on the product's container.

Exterior Cleaning

A mild household soap solution and a soft brush can be used to clean all the exterior of your Imperial RV.

- Wash the exterior monthly with warm water and a mild detergent.
- Avoid spraying water directly into refrigerator and furnace vents.
- Immediately remove bird droppings, tree sap, insects and tar to avoid staining.
- Wax at least once a year with a standard marine or automotive liquid or paste wax.
- Prolonged storage of unit should be in a sheltered environment if possible.

Keep screens and window slides clean and free of debris. Periodically test the operation of all windows and their components. If you are unsure about the correct methods of lubrication and adjustment, check with your Imperial Dealer.

Storing Your Imperial

When storing your RV, certain precautions need to be taken to protect your unit. The following steps are general and your Imperial Dealer can help you choose those which are most appropriate for your needs.

1. Park your Imperial RV on a level surface
2. Clean your recreational vehicle thoroughly, inside and out, as previously outlined in this section.
3. Winterize the Waste and Fresh water systems, P' traps and Hot Water Heater if equipped.
4. Follow the Winterizing procedure in this manual.
5. Follow all component Manufacturer's instruction regarding their particular components (if their procedure differs from this manual, follow the component Manufacturer's instructions).
6. Follow the Refrigerator Manufacturer's directions for shut down and storing your refrigerator. Empty, defrost, clean the refrigerator, and then install the 'Door Stay Storage Clip(s)' that hold the door(s) open to prevent mold and mildew from forming on this inside of the refrigerator.
7. Drain and allow the insides to dry, any water hoses you use for connection to outside water sources you may be storing inside your Imperial RV and connect the male and female ends of the hoses to prevent contamination.
8. Keep the LP tanks connected and full to prevent contaminants, insects and dirt from entering the gas lines and regulator.
9. Turn the LP gas off at the tanks.
10. Turn off all electrical switches and appliances.
11. Be sure the stove's hood vent damper door is 'locked' on the outside of your Imperial.
12. Close all shades and curtains.
13. Be sure all windows, doors and vents are securely closed and locked.
14. Cover exterior appliance vents to prevent moisture and insects from entering during storage.
15. Be sure the Fresh Water, City Water Connection and Waste Water drain caps are secure.
16. Consider a screened cover for the Waste Water Holding tanks roof vent (available at many RV centers) to keep spiders and wasps out of the Waste Water Holding vent and tank.
17. Consider purchasing and using an RV cover for your Imperial.
18. Check the interior of your Imperial periodically to be sure leaks have not developed or that condensation has not formed, causing damage to interior components. Condensation can be observed as moisture accumulation on windows, mirrors, metal faucets and metal surfaces.
19. Air out the Imperial occasionally during storage ON A DRY, LOW HUMIDITY DAY to reduce the possibility of condensation.
20. Be sure that both the electric brake's battery, hydraulic or electric drop down battery and auxiliary battery(s) have the proper electrolyte level and that they are fully charged.
21. A discharged battery will freeze and crack the case. In storage, a battery will gradually loose charge after 30-45 days, even when disconnected or when using of the battery disconnect switch. Imperial recommends that you check the battery for charge once a month. If the charge is 80 or less, it must be recharged. You may wish to remove the battery and store it in a heated area and NOT in direct contact with the ground, concrete or asphalt floor (still checking it monthly for a good charge as even when kept in a warm environment the battery level must be maintained).
22. Consider storing your Imperial where external power can keep the Power Converter running which will keep the battery charge/maintenance charger running and the battery(s) will remain charged and maintained throughout the storage period.
23. Be sure the tires are inflated to correct pressure and check them periodically.
24. Consider covering your tires to keep the sun from drying them out.
25. Consider parking your tires on wood planks.
26. Keep the roof free from leaves, snow and ice. Check it periodically and after a heavy snowfall.

Winterizing Your Imperial

Rev. 09-2025

Winterizing Plumbing Lines and Fixtures "WINTERIZE"

1. Turn handles to "TANK FILL" position as shown.

- **BLUE** diverter handle should be facing down.
- **GREEN** diverter handle should be facing left.



2. Open low point drain(s) on RV to remove water in plumbing lines. Open both a hot and cold faucet to help drainage process.

3. Open drain plug on hot water heater to drain water if unit is equipped with hot water holding tank.

NOTE: Contact your dealer or manufacturer for exact location of low point drains and hot water heater.

4. Once most water has been drained from plumbing lines, turn **BLUE & GREEN** handles so they are at a 45 degree angle as shown.



5. Using "CITY WATER" inlet or low point drain, blow out plumbing lines (40 PSI max) with handles still at 45 degree angle as shown. This will ensure any trapped water in plumbing harness is removed.

6. Close drains on hot water tank & low point drains

7. Remove apparatus used to blow out plumbing lines from "CITY WATER" inlet.



7. Turn handles to "WINTERIZE" position as shown.

- **BLUE** diverter handle should be facing right.
- **GREEN** diverter handle should be facing left.

8. Connect a short section of garden hose to inlet labeled "SANITIZE / WINTERIZE."

Important !!! Make sure you BY-PASS your water heater if your unit requires it. Contact your RV manufacturer for more information.



9. Place other end of garden hose in container holding approved winterizing solution.



NOTE: A short or cut off section of garden hose should help the pump to prime easier.

10. Push "PUMP" switch to turn pump on.

NOTE: LED indicator light below the pump switch will be lit if pump has power.



11. Pump should be running and winterizing solution should begin to flow through pump into plumbing lines and fixtures.

NOTE: The pump will run when a plumbing fixture is open.

12. Open one plumbing fixture, keeping it open until winterization solution appears, then close.
13. Follow above procedure until all inside & outside plumbing fixtures have been winterized hot & cold sides of plumbing fixtures.

Important! Make sure to run winterizing solution through hot & cold lines on exterior shower.

14. Push "PUMP" switch to turn off pump.

NOTE: LED indicator light below the pump switch will not be lit.



15. Disconnect garden hose from "CITY WATER" inlet.

NOTE: It is normal for some winterizing solution to be present as hose is being disconnected.

Winterizing Your Imperial

Rev. 09-2025

Winterizing your Truma Combi

The Truma Combi's water container must be drained to avoid damage whenever there is a risk of frost while your RV is not in use. After draining the water, the Combi furnace is protected against freezing conditions.

Step 1: Begin by turning off the Truma Combi and give the unit time to cool down. Place a vessel that's at least 2.64 gallons (10 liters) underneath the drainage outlet of the drain valve, to catch the drained water. Make sure all of the water drains from the Combi.

Step 2: Use the main switch or pump switch to switch off the power to the water-pump.

Step 3: Turn off or disconnect the city water connection, if present.

Step 4: Open all water release points, e.g. cold and hot water faucets, showers, toilets. The unit should be placed in bypass in accordance with the manufacturer's instructions.

Step 5: Flip yellow handle "up" to be in line with valve body to drain. The water container will drain via the drainage outlet of the drain valve. Leave the drain valve open for the winter season. Make sure all of the water drains from the Combi. If the water does not drain, check the clear tube for obstructions. (Call Truma Service if you need assistance at 1-855-558-7862 ext. 1)

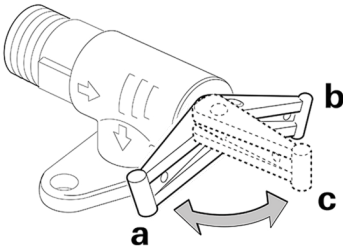

Flip yellow handle "up" to be in line with valve body to drain.

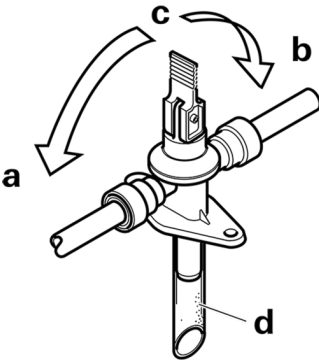

a, b = lever in "valve closed during furnace operation" position

c = lever in "draining" position

d = drainage socket

Winterizing your RV with a winterizing fluid is only possible with an installed bypass kit, refer to the complete manufactures manual for more details. And remember, the use of high pressure air is not recommended.

Formaldehyde from Building Materials

Certain building products such as particleboard, fiberboard and hardwood plywood are manufactured with an adhesive containing urea-formaldehyde. These products emit a small quantity of formaldehyde into the air. Other products containing formaldehyde or formaldehyde resins are used in some carpets, draperies, upholstery, fabrics, deodorizers, cosmetics and permanent press fabrics. Formaldehyde is also a by-product of combustion and is produced by cigarettes and gas appliances.

The concentration of formaldehyde in the indoor air depends upon the quantity and emission rates of all emitting products in the structure compared to the volume of indoor air and the fresh air ventilation rate. As with other indoor pollutants, ventilation should reduce formaldehyde levels.

Component List / Manufacturer Info (if equipped, components subject to change)

Rev. 09-2025

	Manufacturer	Phone#	Website	Warranty Term
Bathroom Fan	MaxxAir by AirExcel	(574) 247-9235	www.maxxair.com	2 yr
Refrigerator	Dometic	(800) 544-4881	www.dometic.com	5 yr
Cooktop	Dometic	(800) 544-4881	www.dometic.com	1 yr
DC to DC Charger	Victron	contact Imperial Dealer	www.victronenergy.com	5 yr
Inverter Charger	Victron	contact Imperial Dealer	www.victronenergy.com	5 yr
CerboGX	Victron	contact Imperial Dealer	www.victronenergy.com	5 yr
Solar Controller	Victron	contact Imperial Dealer	www.victronenergy.com	5 yr
Batteries	Expion360	(541) 797-6714	www.expion360.com	12 yr
Solar Panels	GoPower	(866) 247-6527	www.gpelectric.com	25 yr
Air Conditioner	Dometic	(800) 544-4881	www.dometic.com	1 yr
	Velit	(425) 678-2167	www.velitcamping.com	1 yr
Furnace	Truma	(855) 558-7862	www.truma.net	2 yr*
Water Heater	Truma	(855) 558-7862	www.truma.net	2 yr*
Thermostat	Truma	(855) 558-7862	www.truma.net	2 yr*
Water Pump	Sea Flo	0086 592 5930656	http://www.seaflo.com/en-us/	1 yr
Water Management System	B&B Moulders	(574) 259-7838	www.bandbmolders.com	1 yr
Suspension	Cruisemaster	contact Imperial Dealer	www.cruisemaster.com.au	5 yr*
Tires	Maxxis	(800) 4MAXXIS	www.maxxis.com	50k mi
Stabilizer Jacks	ARK	(630) 723-0072	www.arkcorporation.us	1 yr
Tongue Jack	ARK	(630) 723-0072	www.arkcorporation.us	1 yr

* with online product registration

REPLACEMENT PARTS	Manufacturer	Info	Part#
Wheel Bearing Kit	Cruisemaster	OB120 = Qty 2	10-VT
Tire Size	MAXXIS	RAZR AT-S	LT245/75 R16
Brake Shoe Kit	Cruisemaster	OB120 = QTY 2	(no p/n: 12" Drum)
Hitch Pin	Cruisemaster	DO35	18D-DO35-TP-WF-1-INCH-KIT
G30 Shock Absorber	Cruisemaster	For CRS2 Suspension	33J-2700-CRS2

Replacement brake and suspension parts can be found at <https://cruisemaster.com.au/shop/>. If you are having trouble finding a replacement part, we can help you locate what you need. We do stock limited quantities of common replacement parts for your convenience. Email us at info@nel-industries.com for assistance.



manufactured by **Nelson Industries, Inc.** | 2191 Aspen Street, St. Croix Falls, WI, 54024
www.imperial-outdoors.com | info@imperial-outdoors.com | 715.483.9955