



TECHNICAL MANUAL

HYDRASTAR® HYDRAULIC TRAILER BRAKE ACTUATORS

HBA-10, HBA-12, HBA-16

MHBA-10, MHBA-12, MHBA-16



TABLE OF CONTENTS

Warnings / Requirements (3)
Wiring Schematic / Electrical Requirements (5)
Installation (7)
Brake Line Routing (9)
Electrical Testing (10)
Bleeding Procedure (11)
Adjusting / Gain Control (13)
Troubleshooting (14)
Replacement / Additional Parts (16)
Compatibility Chart (17)
Warranty (19)

WARNINGS / REQUIREMENTS

VISIT WWW.HYDRASTARUSA.COM FOR THE CURRENT COMPATIBILITY CHART FOR FACTORY INTEGRATED BRAKE CONTROLLERS AND AFTERMARKET BRAKE CONTROLLERS.

**Always check your tow vehicle manufacturer owner's manual for compatibility with electric over hydraulic actuators*

SELECT APPROPRIATE PRESSURE RATING ACTUATOR

BRAKE TYPE	RECOMMENDED HYDRASTAR
Hydraulic Drum	HBA/MHBA-10 (1000 psi)
Hydraulic Drum, Above 8K Rating**	HBA/MHBA-12 (1200 psi)
Hydraulic Disc**	HBA/MHBA-16 (1600 psi)

*Hydrastar™ brake actuators are rated for 1-3 axles, and in most cases, 4 axle configurations.

**As a general rule, hydraulic drum brakes require the HBA/MHBA-10 (1000 psi) for axles rated up to 8k. Axles with drum brakes rated at 8k or higher may use the HBA/MHBA-12 (1200 psi) if the brake manufacturer rates their brakes for the additional psi. Disc brakes typically require the HBA/MHBA-16 (1600 psi). With lighter disc brakes, the HBA/MHBA-12 (1200 psi) may be adequate.

ALWAYS CHECK WITH THE BRAKE MANUFACTURER BEFORE CHOOSING A HYDRASTAR™ BRAKE ACTUATOR

Hydrastar, manufacturer of the HYDRASTAR™ brake actuator, cannot be held responsible or liable for manufacturer's claims regarding brake pressure and number of axles.

DO NOT ATTEMPT TO UNSCREW THE WIRE STRAIN RELIEF ON THE FRONT OF THE HYDRASTAR. IT IS NOT REMOVABLE!



MUST BE PROPERLY SIZED FOR THE TOWING COMBINATION

The Hydrastar™ actuator is intended to provide flow and pressure to the brake system on the towed vehicle in accordance with applicable state and federal laws. It is the sole responsibility of the installer to see that the actuator is properly sized with the brake system on the towed vehicle so that the time required to build pressure in the towed vehicle brake system is not excessive.

PROPER INSTALLATION REQUIRED FOR PROPER OPERATION

The Hydrastar™ actuator must be installed by a qualified individual. Failure to properly install, protect, operate, and maintain the system can cause malfunction resulting in possible serious or fatal injuries and or property damage.

NOT INTENDED TO BE USED AS A PARKING BRAKE

The Hydrastar™ actuator and trailer brakes are only intended to supplement the service brake system on the towing vehicle. The Hydrastar™ actuator and trailer brakes are not designed to function as a parking brake. The towed vehicle brake system (trailer) should not be used as the primary source of braking for the towing vehicle.

BREAKAWAY BATTERY REQUIREMENT

To comply with federal requirements, the trailer must be equipped with a breakaway switch and battery. The breakaway battery must have a minimum capacity of 5-amp hours and needs to be maintained in a fully charged condition at all times. The breakaway battery should be checked for proper charge level before every use.

EMERGENCY BREAKAWAY BATTERY MUST BE CHARGED

Do not attempt to tow the towed vehicle unless the emergency breakaway battery is fully charged.

IN-CAB ELECTRONIC BRAKE CONTROLLER REQUIRED

The Hydrastar™ actuator is intended to be used with an in-cab electronic brake controller. The unit will operate with a wide variety of controllers but provides optimum performance when used with a CTS electronic brake controller. Contact your dealer for a list of approved brake controllers. The list is also available online at www.hydrastarusa.com under the resources tab. The in-cab controller must have an output capacity of at least 5 amps for proper operation of the Hydrastar™ actuator.

WIRING SCHEMATIC / ELECTRICAL REQUIREMENTS

WIRE SIZE / LOW VOLTAGE CONDITION

It is critical that the BLACK power lead and WHITE ground lead from the tow vehicle to the input of the Hydrastar™ actuator are sized and terminated, (i.e. dedicated 25-40* amp circuit on the tow vehicle – 12-gauge wire minimum). 10-gauge wire is recommended to optimize performance. Consult the SAE wiring guidelines for proper trailer electrical harness design.

It is critical that the wire from the in-cab electronic brake control is connected to the BLUE wire on the Hydrastar™ actuator. It is also critical that the YELLOW wire from the Hydrastar™ actuator is connected to the cold side of the trailer emergency breakaway switch. Under no circumstances should the solid blue wire and the yellow wire be connected together.

**Cold temperature (below 0° F) applications require 40 amp.*

ELECTRICAL CONNECTIONS

Make sure all electrical connections are clean, dry, weather tight, and secure to prevent damage to the wiring from dragging or becoming entangled with foreign objects. Hydrastar™ highly recommends soldering all electrical connections. A dedicated ground connection between the tow vehicle and trailer is also required.

BLACK WIRE- 12 Volt constant power from the tow vehicle

BLUE WIRE- Power/Signal from the tow vehicle's electronic brake controller

WHITE WIRE- Ground from the tow vehicle and to the trailer

YELLOW WIRE- Emergency breakaway power leads to cold side of breakaway switch

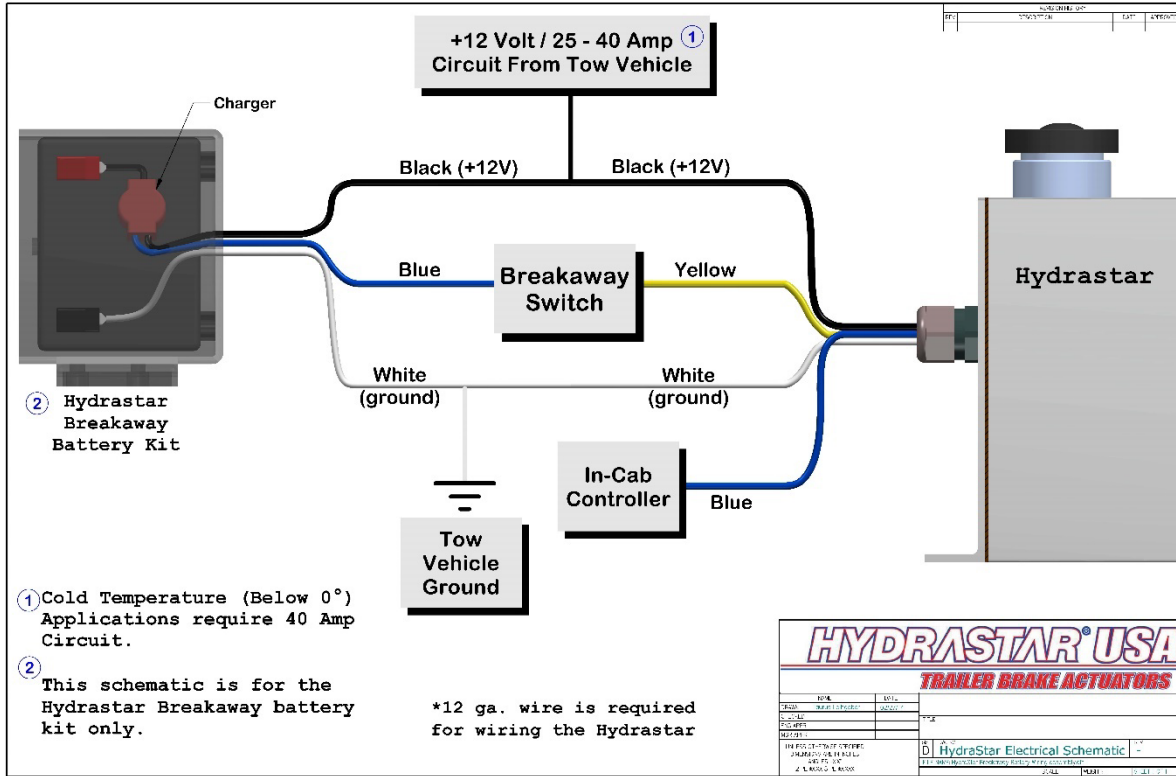

IMPORTANT – CONSULT YOUR VEHICLE OWNER’S MANUAL

Be sure to review your vehicle owner’s manual to see what it says about vehicle to trailer wiring. More and more vehicles manufacturers are recommending that special precautions are taken to protect the more sophisticated electronics on the newer model vehicles.

THE HYDRASTAR™ IS DESIGNED TO BE POWERED FROM THE TOW VEHICLE’S POWER SUPPLY

INSTALLATION

CAUTION

1. Wheels must be properly blocked to prevent the trailer and tow vehicle from rolling.
2. In stop and go traffic, the unit can get quite warm to the touch. This is normal and should not be of concern. Care should be taken to locate the unit in an area where your skin will not come into direct contact with the unit.
3. The Hydrastar™ unit contains sensitive electronics that must be protected. Drilling additional holes in the housing or electrostatically painting the Hydrastar™, or welding anywhere on the Hydrastar™ unit will damage the unit, making it inoperable and will void the manufacturer's warranty. Always remove the Hydrastar™ from the trailer before doing any welding repair or modifications to the trailer structure.
4. Always use new, DOT 3 or DOT 4 brake fluid, from a sealed container. Never attempt to reuse old or dirty fluids. Do not overfill the unit. Fill unit to the bottom of the neck. Take care to protect painted surfaces from contacting the brake fluid. Wash off any spilled brake fluid.
5. Do not attempt to tow the towed vehicle unit until the emergency breakaway battery is fully charged.

The following is necessary for the installation of the Hydrastar™ actuator:

1. 3/16" or 1/4" brake line and fittings (1/4" adapter required, part #43-9035)
2. Mounting hardware (The Hydrastar™ has 2 mounting bracket options, both with 2 pre-drilled holes)
3. Electrical tools and connectors
4. DOT 3 or DOT 4 brake fluid
5. Breakaway Battery Kit

LOCATION

Location of the Hydrastar™ actuator is at the discretion of the owner. When determining location, considerations should be given to the following:

1. The shorter the brake lines are between the Hydrastar™ unit and the trailer brakes, the faster the brakes on the trailer will respond.

2. The unit should be located so that the electrical wiring and brake lines can be neatly routed directly to the towing vehicle and trailer brakes. Special care should be taken to minimize the number of bends and fittings in the brake line routing. (See pages 9-10 for brake line routing models on single, tandem, and triple axle trailers)
3. An emergency breakaway kit must be located on the trailer so that the trailer breakaway cable can be easily attached to the towing vehicle.
4. The Hydrastar™ actuator is powered from the electrical system on the tow vehicle. For the Hydrastar™ unit to function properly, it must have adequate electrical power.
5. The Hydrastar™ unit should not be placed in an area where it is susceptible to damage from trailer loads, road debris, or being stepped on. Failure to protect the Hydrastar™ unit from damage can cause the unit to malfunction and void the Hydrastar™ warranty.
6. The Hydrastar™ unit must be level, with the filler neck up.

BRAKE LINE CONNECTION

1. Remove the red plastic plug from the brake port on the Hydrastar™ unit. This will expose a 3/16" or 1/4" inverted flare fitting (part # 43-9035).
2. Brake line must be compatible with DOT 3 & DOT 4 brake fluid.
3. It is recommended to flush the existing brake system and lines with mineral spirits (NOT mineral oil).
4. Connect the brake line from the trailer brakes to the 3/16" or 1/4" inverted flare fitting on the Hydrastar™ actuator.
5. Add DOT 3 or DOT 4 brake fluid to the Hydrastar™ actuator. Fill up to the bottom of the neck on the Hydrastar™.

MISCELLANEOUS/OTHER FACTORS

1. Ensure the location gives you access to run wires and brake lines.
2. Secure the Hydrastar™ using the mounting brackets on the Hydrastar™.
3. A dampening material may be used under the Hydrastar™ to reduce vibrations when the pump is running.
4. If wires/brake lines will be ran through floors or bulkheads, use grommets to ensure no chaffing occurs.

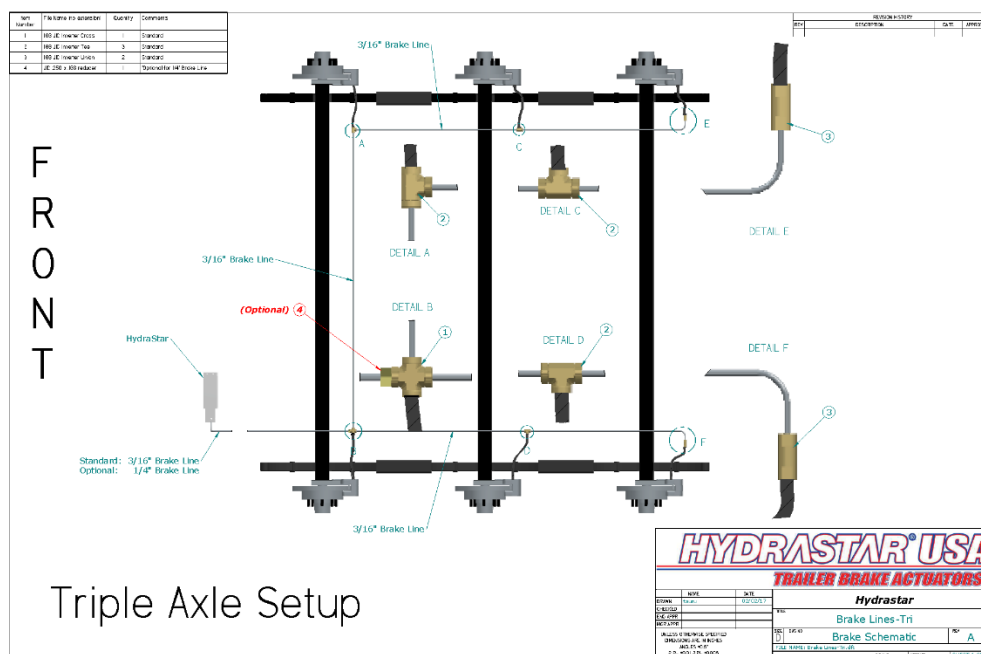

ELECTRICAL TESTING

CAUTION

Testing the Hydrastar™ unit confirms that it is operating, it does not confirm that the brakes are operating properly. Regular inspection, adjustments, and maintenance of the brakes, lines, hoses, drums, discs, calipers, fluid, and other associated components is necessary to ensure proper brake operation.

1. Attach trailer to the towing vehicle.
2. Pull the breakaway switch, the Hydrastar™ unit should run. If the unit does not run, check battery condition and system wiring. Reset the breakaway switch to turn the unit off. **When the unit is running, the motor will generate a “hum” that changes pitch as the unit builds pressure*
3. Turn the ignition switch on and ensure the in-cab brake controller is energized. The Hydrastar™ unit should run whenever the brake pedal is depressed. If the unit does not run, check the system’s wiring.

BLEEDING PROCEDURES

CAUTION

1. Failure to properly adjust the brakes on trailers equipped with drum brakes can result in sluggish operation of the Hydrastar™ unit. Eye protection should be worn at all times while bleeding the Hydrastar™ unit and trailer brake system.
2. Do not run the Hydrastar™ unit without adequate brake fluid in the reservoir as it will damage the unit and void the manufacturer's warranty. Check all bleeder screws to ensure that they are securely closed and do not leak.
3. Failure to properly adjust the trailer brakes and to properly fill and bleed the Hydrastar™ unit and brakes may result in sluggish brake performance. This may result in serious or fatal injuries and/or property damage. As a precautionary measure, Hydrastar™ recommends bleeding the brakes a second time after the trailer has been in service for 7-10 days. Hydrastar™ also recommends checking the temperature of the hubs on a regular basis to ensure that the trailer brakes are not dragging.

1. It is typically much easier to bleed the brakes with two people working together or use of a power bleeding device.
2. Special care must be taken to ensure that the Hydrastar™ unit does not run out of brake fluid. Check the fluid level frequently during the bleeding process.
3. Block the wheels on the trailer and towing vehicle.
4. If the trailer is equipped with drum brakes, check that the brake running clearances are properly adjusted, consistent with the trailer manufacturer's recommendations. Even the slightest amount of brake drag will generate heat and will damage the trailer brake system voiding the manufacturer's warranty.
5. Remove the dust cap from the bleed screw on the Hydrastar™ unit and install plastic tubing onto the bleeder.
6. Immerse the free end of the plastic tubing in a clean container partially filled with brake fluid.
7. With eye protection on, open the bleeder screw one half turn on the Hydrastar™ unit. Take care to protect yourself and the trailer from brake fluid expelled from the bleeder.
8. Activate the Hydrastar™ unit by turning on the ignition switch and pressing on the brake pedal or the manual control on the in-cab controller.
9. Watch the free end of the bleeder hose for air bubbles escaping into the container.
10. Continue to bleed until the fluid becomes clear and free of bubbles.

11. Tighten the bleeder screw, turn off the Hydrastar™ unit, and remove the plastic tubing from the bleeder screw. Bleeding of the Hydrastar™ unit is now complete.
12. Install plastic tubing onto the bleeder screw of the wheel cylinder/caliper.
13. Immerse the free end of the plastic tube in a clean container partially filled with brake fluid.
14. With eye protection on, open the bleeder screw one half turn on the wheel cylinder/caliper farthest from the Hydrastar™ unit. (If towed vehicle has multiple axles, always start with the rear axle first.)
15. Activate the Hydrastar™ unit. (Turn the ignition switch on and press on the brake pedal or squeeze the manual override, turned to the maximum gain setting)
16. Watch the free end of the bleeder hose for air bubbles escaping into the clear container. Continue to bleed the wheel cylinder/caliper until the fluid becomes clear and free of bubbles.
17. Tighten the bleeder screw, turn off the Hydrastar™ unit, and remove the plastic tubing from the bleeder screw. Bleeding of the wheel cylinder/caliper is now complete.
18. Refill the Hydrastar™ unit with brake fluid
19. Continue the above process (steps 12 through 18) on the next farthest brake away from the Hydrastar™ unit. Repeat these steps until all of the brakes have been bled.

ADJUSTING/GAIN CONTROL SETTING

CAUTION

The appropriate pressure setting will vary depending on the weight of the load being transported on the trailer, weather conditions, road conditions, brake lining wear, and brake displacement. The "TESTING AND ADJUSTMENT OF ELECTRONIC CONTROLLER UNIT" procedure should be repeated each time the trailer is used. Failure to properly adjust the Hydrastar™ unit may result in poor brake performance which could result in serious or fatal injuries and/or property damage.

1. Adjust the gain setting on the in-cab controller to a mid-range setting.
2. Drive vehicle at 10 to 15 mph.

3. Apply the brakes. If braking is too severe, adjust the gain setting down to decrease the pressure, and retest. If braking is inadequate, increase the gain setting on the in-cab electronic controller and retest.
4. Repeat this process until the brakes respond appropriately.

TROUBLESHOOTING

HYDRASTAR™ IS NOT WORKING

1. Check for proper wiring of the actuator (*See wiring diagram*)
2. Check for proper wire size (12-gauge wire is required)
3. Check for proper ground (must be ground through the tow vehicle and to the trailer)
4. Check to ensure unit is receiving power from the tow vehicle (black= 12-volt constant power, blue = 10-12 volts during brake activation, white = ground)
5. Check for compatibility with the tow vehicle (*see compatibility chart*) ***If HBA-CAM is required, ensure CAM is wired correctly.**
6. If problem is not solved, conduct Battery Test (see Battery Test Procedures)
7. If actuator passes Battery Test the problem is not in the actuator. If the actuator fails the Battery Test, please contact our Technical Department.

HYDRASTAR™ IS “CLICKING”

1. Check for proper wiring of the actuator (*See wiring diagram*)
2. Check for proper wire size (12-gauge wire is required)
3. Check for proper ground (must be ground through the tow vehicle and to the trailer)
4. Check to ensure unit is receiving power from the tow vehicle (black= 12-volt constant power, blue = 10-12 volts during brake activation, white = ground)
5. Check for compatibility with the tow vehicle (*see compatibility chart*) ***If HBA-CAM is required, ensure CAM is wired correctly.**
6. Check Breakaway Battery System wiring. Blue brake controller wiring from the Hydrastar™ should NOT be wired in to the Breakaway Battery System.
7. If the problem is not solved, conduct Battery Test (see Battery Test Procedures)
8. If actuator passes Battery Test the problem is not in the actuator. If the actuator fails the Battery Test, please contact our Technical Department.

DELAYED RESPONSE OF THE HYDRASTAR™

1. Check brake fluid level
2. Re-bleed the trailer braking system (bleed Hydrastar™ first)
3. Check for proper wiring of the actuator (*see wiring diagram*)
4. Check for proper wire size (12-gauge wire is required)
5. Check for proper ground (must be ground through the tow vehicle and to the trailer)

6. Check for compatibility with the tow vehicle (*see compatibility chart*) ***If HBA-CAM is required, ensure CAM is wired correctly.**
7. If the problem is not solved, conduct Battery Test (see Battery Test Procedures)
8. If actuator passes Battery Test the problem is not in the actuator. If the actuator fails the Battery Test, please contact our Technical Department.

LOW/NO PRESSURE (HYDRASTAR™ RUNS)

1. Check brake fluid level
2. Re-bleed the trailer
3. Check for proper wiring of the actuator (*see wiring diagram*)
4. Check for proper wire size (12-gauge wire is required)
5. Check for proper ground (must be ground through the tow vehicle and to the trailer)
6. Check for compatibility with the tow vehicle (*see compatibility chart*) ***If HBA-CAM is required, ensure CAM is wired correctly.**
7. If the problem is not solved, conduct Battery Test (see Battery Test Procedures)
8. If actuator passes Battery Test the problem is not in the actuator. If the actuator fails the Battery Test, please contact our Technical Department.

BREAKAWAY SYSTEM NOT WORKING

1. Check for proper charge on the battery
2. Check for proper wiring of the Breakaway System
3. Check to ensure wires are not corroded
4. Check for proper function of the Breakaway Switch
5. If you are still having issues, contact Hydrastar Technical Department

12V BATTERY TEST

STEPS	OUTCOME
1. Attach BLACK wire to the positive (+) terminal, attach WHITE wire to the negative (-) terminal	Hydrastar™ <u>SHOULD NOT</u> run
2. Attach BLACK wire and BLUE wire to the positive (+) terminal, attach WHITE wire to the negative (-) terminal	Hydrastar™ <u>SHOULD</u> run

****Use a 12 Volt battery source, isolate the wires from the Hydrastar™ when conducting the Battery Test***

BREAKAWAY TEST

3. Attach YELLOW wire to the positive (+) terminal, attach WHITE wire to the negative (-) terminal	Hydrastar™ <u>SHOULD</u> run
----------------------------------------------------------------------------------------------------	------------------------------

HYDRASTAR™ TECHNICAL SUPPORT – 812-655-4544

HYDRASTAR™ TECHNICAL SUPPORT EMAIL- info@hydrastarusa.com

REPLACEMENT PARTS/ADDITIONAL PARTS

PART	PART #
Controller Adapter Module (CAM)	381-7073
GM Controller Adapter Module (2024/25)	381-7074 (EOH)
Filler Neck Cap	32-7640
3/16" Brake Line Adapter	192-7089
1/4 " Brake Line Adapter	43-9035
Installation Kit	381-9000
Breakaway Battery Kit	496-82
Hydrastar™ Bracket	304-769

COMPATIBILITY CHART

Compatibility with Integrated and Aftermarket Brake Controllers

This reference is for use only with the HBA/MHBA with the following serial numbers and higher:

HBA-10: 313800+ HBA-12: 705700+ HBA-16: 506100+ MHBA-10/12/16: All

The chart is only applicable for HBA-CAM, 381-7073

<i>Tow Vehicle Manufacturer</i>	<i>Year</i>	<i>Compatible</i>	<i>CAM Needed</i>
FORD ***	2005-2006	YES	NO
	2007-2008	NO	YES
	2009-Current	YES	NO
Dodge/RAM	2010-Current	YES	NO
GM/Chevy */**	2007-2016	NO	YES
	2017-Current	YES	NO
Toyota	2016-Current	YES	NO

* “On MY2014 and later full-size GM trucks, the Integrated Trailer Brake Control System was designed to function with either electric, or electric/hydraulic brakes. In most cases, Hydrastar electric/hydraulic trailer brake systems will operate on these vehicles without issue. In some cases, the vehicle may have issues detecting the presence of the trailer's electric brake system, and the vehicle integrated trailer brake control system will not operate. If this issue is observed, adding a Hydrastar Controller Adapter Module 381-7073 to the trailer's brake system can help the vehicle detect the trailer brake system” - General Motors Trailing Division

** 2024 GM/Chevrolet Integrated Brake Controllers may be under factory recall. Check with a certified GM/Chevrolet Service Facility. Ref. Service Bulletin 23-NA-149

*** 2024 GM/Chevy Update

The following chart depicts the starting serial number for units fitted for compatibility with the 2024+ GM/Chevy brake controller

HBA-10	381-7065	340 354
HBA-12	381-7066	737 660
HBA-16	381-7067	591 001
MHBA-10	381-8065	200 730
MHBA-12	381-8066	402 262
MHBA-16	381-8067	617 974
PP MHBA-16	PP391-8067	108 015

**** 2021-2022 Ford recall caused by a software error that may cause the trailer brakes to fail. The recall includes: F-150, F-250, F-350, F-450, F-550, Maverick, Expedition, and Lincoln Navigators. Certified service facilities will update the integrated brake control module software, free of charge. Check NHTSA website for recalls against vehicle VIN.

AFTERMARKET BRAKE CONTROLLERS

Most current aftermarket brake controllers are compatible with EOH technology, but you should always check with the controller manufacturer to ensure compatibility.

Hydrastar™ cannot guarantee or be held liable for the accuracy of manufacturer's claims regarding compatibility.

WARRANTY

I. LIMITED WARRANTY AND LIMITATION OF LIABILITY

Brake actuators manufactured and sold by Hydrastar are warranted to be free from defects in material and workmanship under normal and proper use for a period of: (2) two years from vehicle in-service date subsequent to installation of Hydrastar's brake actuator products, or (2) two years from purchase date of a free-standing unit. No claim for breach of warranty will be allowed unless the material or workmanship defect is found within the warranty period, properly documented by buyer and Hydrastar is notified in writing within 30 days of failure. This warranty shall not apply to products altered or utilized in a manner not approved by Hydrastar or subjected to abuse, misuse, improper maintenance, negligence or accident.

THE FOREGOING WARRANTIES ARE EXCLUSIVE AND ARE ACCEPTED BY BUYER IN LIEU OF ANY AND ALL OTHER WARRANTIES, EXPRESSED OR IMPLIED, INCLUDING WITHOUT LIMITATION THE IMPLIED WARRANTIES OF MERCHANTABILITY OR FITNESS FOR PARTICULAR PURPOSE.

Buyer's sole remedy in the event of a breach of the foregoing warranties is the repair or replacement of the affected product by Hydrastar. NO merchandise will be accepted for warranty credit consideration without a Returned Goods Authorization Number issued by the Customer Service Representative (812-655-4544). If, upon inspection by the Returned Goods Technician, the merchandise is found to be free from defects in material and workmanship, then the warranty claim shall be deemed invalid, and the merchandise shall be held for a period of (15) days pending disposition by the buyer and an inspection charge may be applied by Hydrastar.

BUYER AGREES THAT IN NO EVENT, WILL HYDRASTAR'S LIABILITY FOR ALL LOSSES FROM ANY CAUSE, WHETHER BASED ON CONTRACT, NEGLIGENCE, STRICT LIABILITY, OTHER TORT OR OTHERWISE, EXCEED BUYER'S NET PURCHASE PRICE, NOR WILL HYDRASTAR BE LIABLE FOR ANY SPECIAL, INCIDENTAL, CONSEQUENTIAL OR EXEMPLARY DAMAGES.

The foregoing warranties will continue in effect so long as the product is serviced and maintained in accordance with Hydrastar's instructions and with genuine Hydrastar manufactured replacement parts. These warranties may not be altered or amended except by a written instrument signed by the buyer and a duly authorized officer of Hydrastar.